



# KSC-361

## Industrial Ethernet to Serial Media Converters

Firmware Rev1.00 up

User's Manual



DOC.170726

(C) 2017 KTI Networks Inc.

All rights reserved. No part of this documentation may be reproduced in any form or by any means or used to make any derivative work (such as translation or transformation) without permission from KTI Networks Inc.

KTI Networks Inc. reserves the right to revise this documentation and to make changes in content from time to time without obligation on the part of KTI Networks Inc. to provide notification of such revision or change.

For more information, contact:

15F-7, No. 79, Sec. 1, Hsin-Tai-Wu RD

His-chih, New Taipei City, Taiwan

Fax: 886-2-26983873

E-mail: [kti@ktinet.com.tw](mailto:kti@ktinet.com.tw)

URL: <http://www.ktinet.com.tw/>

The information contained in this document is subject to change without prior notice.

Copyright © All Rights Reserved.

## **TRADEMARKS**

Ethernet is a registered trademark of Xerox Corp.

## **FCC NOTICE**

This device complies with Part 15 of the FCC Rules. Operation is subject to the following two conditions: (1)

This device may not cause harmful interference, and (2) This device must accept any interference received, including the interference that may cause undesired operation.

## **CE NOTICE**

Marking by the symbol indicates compliance of this equipment to the EMC directive of the European Community. Such marking is indicative that this equipment meets or exceeds the following technical standards:

EN 61000-6-4 Class A

EN 61000-3-2, EN 61000-3-3

EN 61000-6-2

IEC 61000-4-2, IEC 61000-4-3, IEC 61000-4-4

IEC 61000-4-5, IEC 61000-4-6, IEC 61000-4-8

IEC 61000-4-11

## **VCCI-A Notice**

この装置は、クラスA情報技術装置です。この装置を家庭環境で使用すると電波妨害を引き起こすことがあります。この場合には使用者が適切な対策を講ずるよう要求されることがあります。 VCCI-A

# Table of Contents

<b>1. Introduction</b> .....	<b>7</b>
1.1 Features.....	8
1.2 Product Panels.....	8
1.3 LED Indicators.....	10
1.4 Specifications.....	10
<b>2. Installation</b> .....	<b>15</b>
2.1 Unpacking.....	15
2.2 Safety Cautions.....	15
2.3 DIN-Rail Mounting.....	16
2.4 Panel Mounting.....	18
2.5 Applying Power.....	20
2.5.1 Direct Power via Terminal Block.....	20
2.5.2 Direct Power via DC Power Jack.....	21
2.5.3 PoE via RJ-45.....	22
2.6 Alarm Relay Output.....	23
2.7 Reset Button.....	24
2.8 Making RJ-45 Port Connections.....	25
2.9 Making SFP Fiber Connection.....	26
2.10 Selection of Copper RJ-45 or Fiber SFP.....	27
2.11 Setting DIP Switches.....	27
2.11.1 4-Wire/2-Wire Bus.....	28
2.11.2 Receiver Terminator.....	28
2.11.3 ADC.....	29
2.11.4 Line Bias.....	29
2.12 Making RS-232 Connection.....	30
2.12.1 Making PC Connection via COM Port.....	30
2.13 Making RS-422/485 2-Wire Connection.....	31
2.14 Making RS-485 4-Wire Connection.....	31
2.15 LED Indication.....	32
<b>3. Application Modes</b> .....	<b>33</b>

3.1 Remote COM Mode .....	33
3.2 Pair Connection Mode .....	34
3.3 Serial Server Mode .....	34
3.4 Serial Broadcasting Mode .....	35
3.5 Reverse Telnet Mode .....	35
<b>4. Configuring IP Address &amp; Password.....</b>	<b>36</b>
4.1 IP Address & Password.....	36
4.2 Configuring IP Address & Password via console .....	36
4.3 Configuring IP Address via Web Interface .....	36
<b>5. Web Management .....</b>	<b>38</b>
5.1 Login .....	38
5.2 Main Menu .....	38
5.3 System Host Configuration.....	39
5.4 Application Configuration.....	40
5.5 TCP Control Configuration .....	41
5.5.1 Selecting Application Mode .....	43
5.6 UDP Control Configuration .....	44
5.6.1 UDP Master Configuration.....	44
5.6.2 UDP Slave Configuration.....	45
5.7 Serial Port Control Configuration .....	46
5.8 Event Notification .....	48
5.8.1 Notification via SNMP Trap and Email.....	48
5.8.2 Notification Events.....	49
5.9 Statistic Overview.....	49
5.10 Ping.....	50
5.11 Reboot System.....	50
5.12 Restore Default .....	51
5.13 Firmware Update.....	51
5.14 Logout.....	54
<b>6. Console Commands.....</b>	<b>55</b>
6.1 Connecting Console .....	55

6.2 Console Command Sets.....	55
<b>Appendix 1. RS-422 / RS-485.....</b>	<b>58</b>
A1.1 RS-422 Point-to-Point Circuit.....	59
A1.2 RS-422 Multi-drop Network.....	59
A1.3 RS-485 Multi-drop Network.....	59
A1.4 RS-485 Half-duplex 2-wire Network.....	60
A1.5 RS-485 Full-duplex 4-wire Network.....	60
<b>Appendix 2. VCOM Program for Windows.....</b>	<b>61</b>
A2.1 Functions of VCOM.....	61
A2.2 Installing the VCOM Program.....	61
A2.3 VCOM Program Operation.....	63
A2.4 Alternative Solution beside VCOM Program.....	65

# 1. Introduction

The KSC-361 product series are industrial rated Ethernet to serial media converters. Two models are described in this documentation. They are:

Model Number	KSC-361-S2	KSC-361-S4
Ethernet Interface	10/100Mbps RJ-45 10BASE-T, 100BASE-TX	10/100Mbps RJ-45 10BASE-T, 100BASE-TX
Fiber Interface	SFP 100BASE-FX	SFP 100BASE-FX
Serial Interface	DB9 RS-232	Terminal Block RS-422/RS-485
Photo		

## 1.1 Features

- Ethernet interface provides combo port of 10/100Mbps copper RJ-45 and 100M fiber SFP slot.
- Serial interface provides two options of RS-232 and RS-422/485.
- Serial port supports baud-rate up to 230400bps.
- Galvanic isolation on serial interface
- Data conversion throughput up to 230Kbps
- Wide range of direct power voltage support, DC 8V-60V
- Powered over Ethernet through RJ-45 interface (PoE-enabled)
- Alarm relay output for power failure, port link down and failure in connecting to server
- Application support for remote COM port, serial server over TCP, reverse telnet, pair connection, and serial broadcast
- Remote COM driver support for Windows PC
- Web-based and serial-based console configuration
- Event notification over SMTP and SNMP traps

## 1.2 Product Panels

The following figure illustrates the front panel and rear panel of the models:

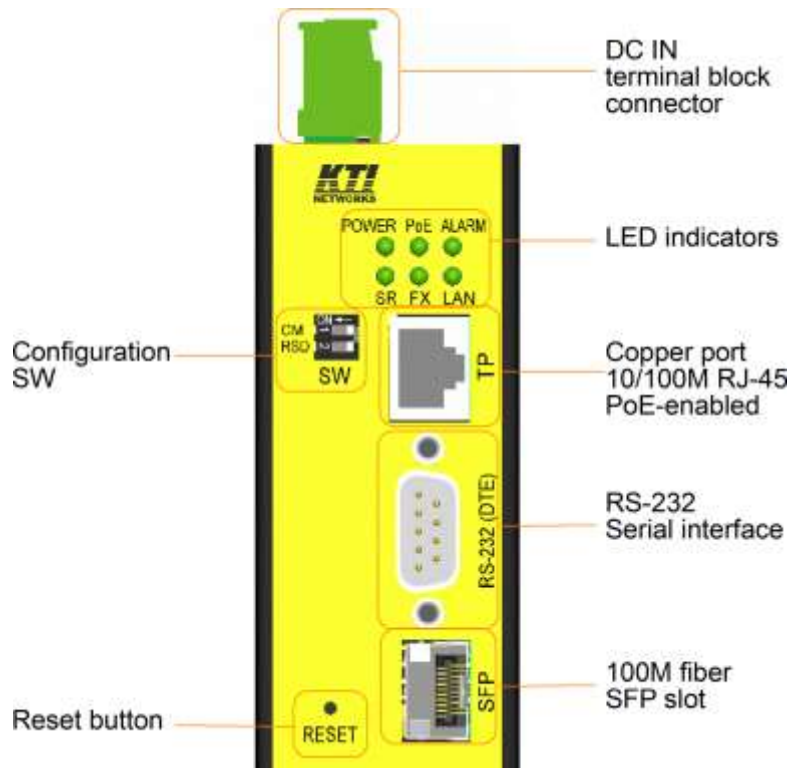

**KSC-361-S2 Front panel**



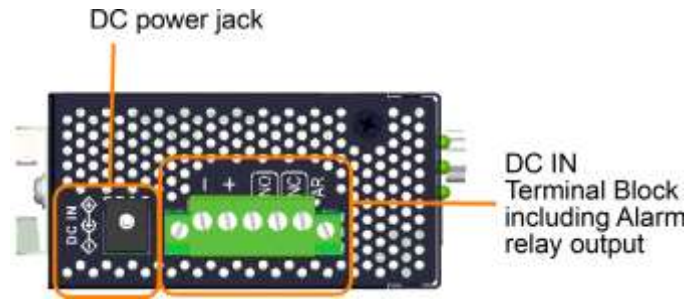

**KSC-361-S2 Top Panel**

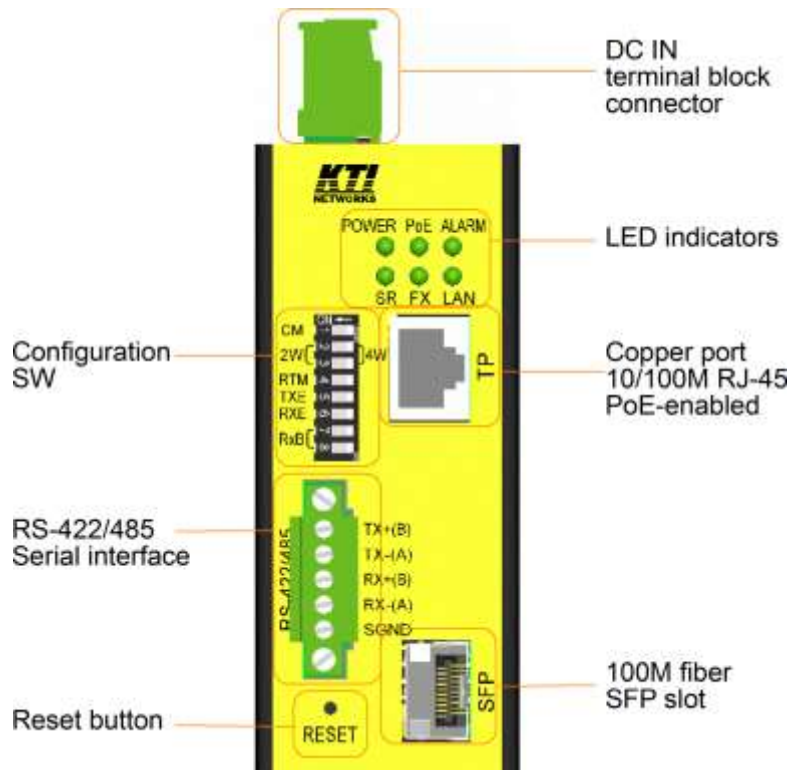

**KSC-361-S4 Front panel**

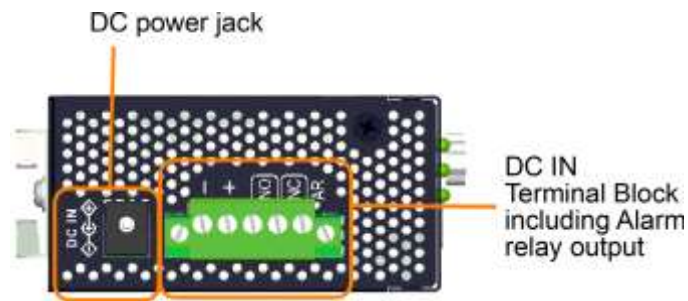

**KSC-361-S4 Top Panel**

## 1.3 LED Indicators

<b>LED</b>	<b>Function</b>
POWER	Power status
SR	Serial interface activity status
PoE	Powered by PoE input
FX	Fiber SFP is selected
ALARM	Alarm status (& Diagnostic status during boot-up)
LAN	Ethernet interface link & activity status

## 1.4 Specifications

### Ethernet Copper Port 10/100 RJ-45

Compliance	IEEE 802.3 10Base-T, IEEE 802.3u 100Base-TX
Connector	Shielded RJ-45 jack
Pin assignments	Auto MDI/MDI-X detection
Configuration	Auto-negotiation
Transmission rate	10Mbps, 100Mbps
Duplex support	Full/Half duplex
Flow control	Enabled
Network cable	Cat.5 UTP up to 100 meters
Pin assignments	MDI-X

Pin	Signal
1	RX+
2	RX-
3	TX+
4	-
5	-
6	TX-
7	-
8	-

PoE	PD Class 3
-----	------------

### Ethernet 100M Fiber SFP Slot

Compliance	IEEE 802.3u 100Base-FX
Connector	SFP for optional SFP type fiber transceivers
Configuration	Fixed 100Mbps, Full duplex
Transmission rate	100Mbps

Network cables MMF 50/125 60/125, SMF 9/125  
 Eye safety IEC 825 compliant

**RS-232 Serial Interface (KSC-361-S2)**

Interface RS-232  
 Connector Male DB9  
 Isolation Galvanic isolated  
 Pin assignment DTE type

Pin	Signal
1	-
2	RX
3	TX
4	-
5	GND
6	-
7	-
8	-

Baud Rate Support Up to 230K baud  
 Connector Shield Connect to chassis ground  
 Connection Distance 15 meters  
 Overvoltage Protection Cutoff if over +/-28V

**RS-422/485 Serial Interface (KSC-361-S4)**

Interface RS-422, RS-485  
 Connector Flange terminal block 5P  
 Signal Type Balanced differential lines  
 Data Speed 230Kbps  
 Standard EIA-485, EIA-422  
 Overvoltage Protection Cutoff if over +/-28V  
 Isolation Galvanic isolated  
 Pin assignment

Pin	4-wire bus	2-wire bus
1	TX+	B
2	TX-	A
3	RX+	B

4	RX-	A
5	SGND	SGND

**Configuration Switches (SW)**

KSC-361-S2 RS-232 model

SW	Name	Function
1	CM	Serial interface console mode setting
2	RSD	Reserved

KSC-361-S4 RS-422/485 model

SW	Name	Function
1	CM	Serial interface console mode setting
2	2W-4W	2-wire or 4-wire network setting
3	2W-4W	2-wire or 4-wire network setting
4	RTM	Receiver terminator
5	TXE	Transmitter control
6	RXE	Receiver control
7	RX-B1	RX+ line bias
8	RX-B2	RX- line bias

**DC IN Terminal Block**

Connector Flange terminal block 5P

Contacts Isolated to frame ground

Pin	Marking	Remark
1	DC-	Direct power input (-)
2	DC+	Direct power input (+)
3	NO	Alarm relay NO (Normal Open) output
4	Common	Alarm relay common contact for NO and NC
5	NC	Alarm relay NC (Normal Close) output

Operating input voltages +8 ~ +60VDC

Power consumption 2W max. @24V

3W max. @48V via PoE

Alarm relay output 3 contacts (Rating: 30VDC/1A max. or 120VAC/0.5A max.)

NC contacts: normal – shored, alarm – open

NO contacts: normal – open, alarm – shored

Alarm events Power failure

Ethernet port link fault  
Failure in connecting to server

### **DC Power Jack**

Connector DC Jack (-D6.3mm/+D2.0mm) for external AC-DC power adapter  
Center contact DC+ D2.0mm  
Outer contact DC- D6.3mm  
Operating voltages DC input +8V ~ +30V  
Power consumption 2W max. @24V

### **Power over Ethernet Function on RJ-45**

Standard IEEE 802.3af PD (Powered Device)  
Power classification Class 3  
Working voltage +36V ~ +57V  
Pin assignment RJ-45 PoE power pins

Pin	PoE IN
1	V+
2	V+
3	V-
4	V+
5	V+
6	V-
7	V-
8	V-

### **Mechanical**

Dimension 40 x 80 x 95 mm (Case WxDxH)  
Housing Enclosed metal with no fan  
Mounting Din-rail mounting, Panel mounting (optional)

### **Environmental**

Operating Temperature Typical -30°C ~ +70°C  
Storage Temperature -40°C ~ +85°C  
Relative Humidity 5% ~ 90% non-condensing

### **Electrical Approvals**

FCC Part 15 rule Class A

CE

VCCI

Safety / LVD

EMC Class A

Class A

IEC 60950-1

## 2. Installation

---

### 2.1 Unpacking

The product package contains:

- The device unit
- One product CD-ROM

### 2.2 Safety Cautions

To reduce the risk of bodily injury, electrical shock, fire and damage to the product, observe the following precautions:

	Do not service any product except as explained in your system documentation.
	Opening or removing covers may expose you to electrical shock.
	Only a trained service technician should service components inside these compartments.
	If any of the following conditions occur, unplug the product from the electrical outlet and replace the part or contact your trained service provider: <ul style="list-style-type: none"><li>- The power cable, extension cable, or plug is damaged.</li><li>- An object has fallen into the product.</li><li>- The product has been exposed to water.</li><li>- The product has been dropped or damaged.</li><li>- The product does not operate correctly when you follow the operating instructions.</li></ul>
	Do not push any objects into the openings of your system. Doing so can cause fire or electric shock by shorting out interior components.
	Operate the product only from the type of external power source indicated on the electrical ratings label. If you are not sure of the type of power source required, consult your service provider or local power company.

## 2.3 DIN-Rail Mounting

In the product package, a DIN-rail bracket is provided for mounting the device in industrial DIN-rail enclosure. The steps to mount the device onto a DIN rail are:

1. Install the mounting bracket onto the switch unit as shown below:

**KSC-361-S2 (RS-232 model)**

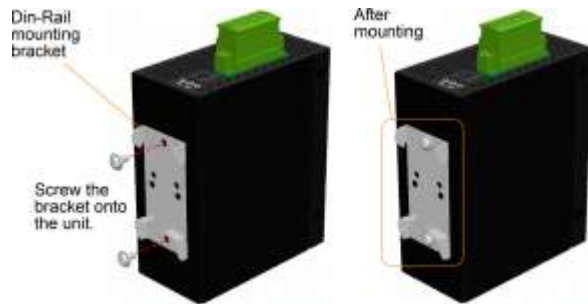

**KSC-361-S4 (RS-422/485 model)**

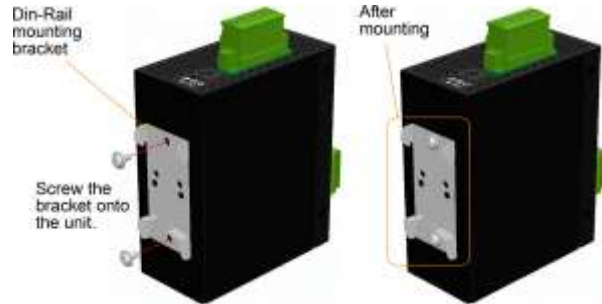

2. Attach bracket to the lower edge of the DIN rail and push the unit upward a little bit until the bracket can clamp on the upper edge of the DIN rail.
3. Clamp the unit to the DIN rail and make sure it is mounted securely.

**KSC-361-S2 (RS-232 model)**

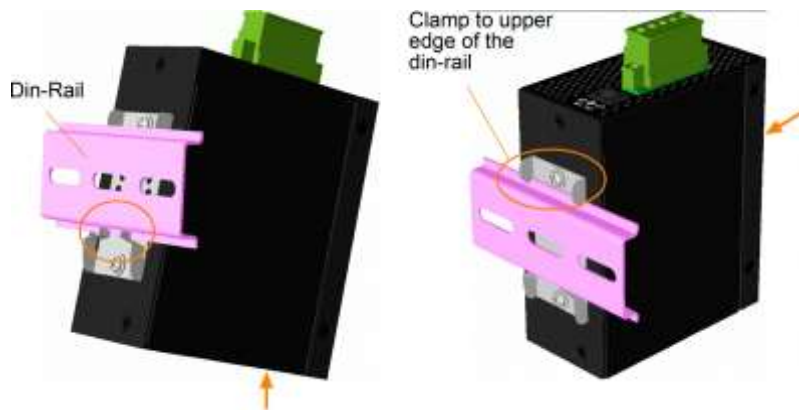

**KSC-361-S4 (RS-422/485 model)**

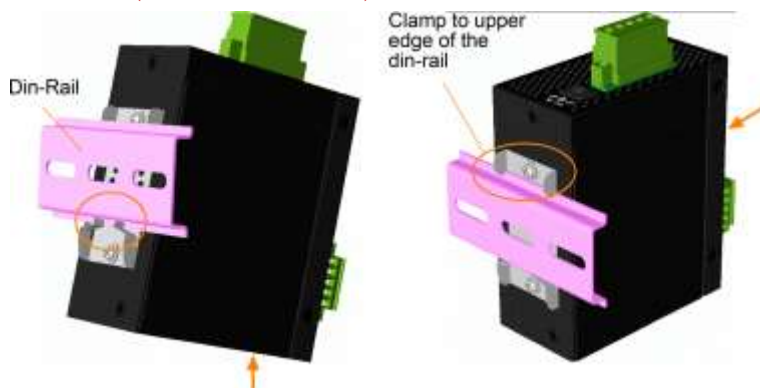



**Dimensions:**

**KSC-361-S2 (RS-232 model)**

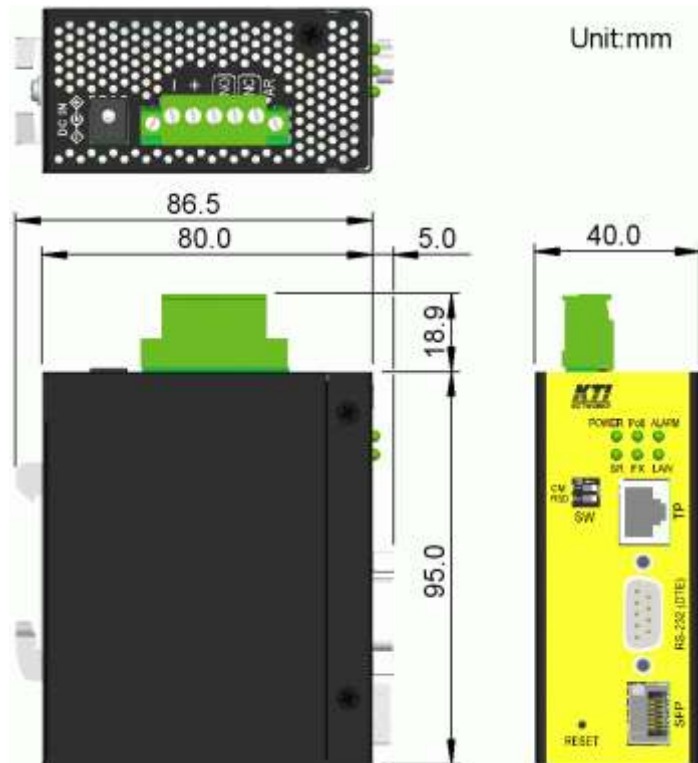

**KSC-361-S4 (RS-422/485 model)**

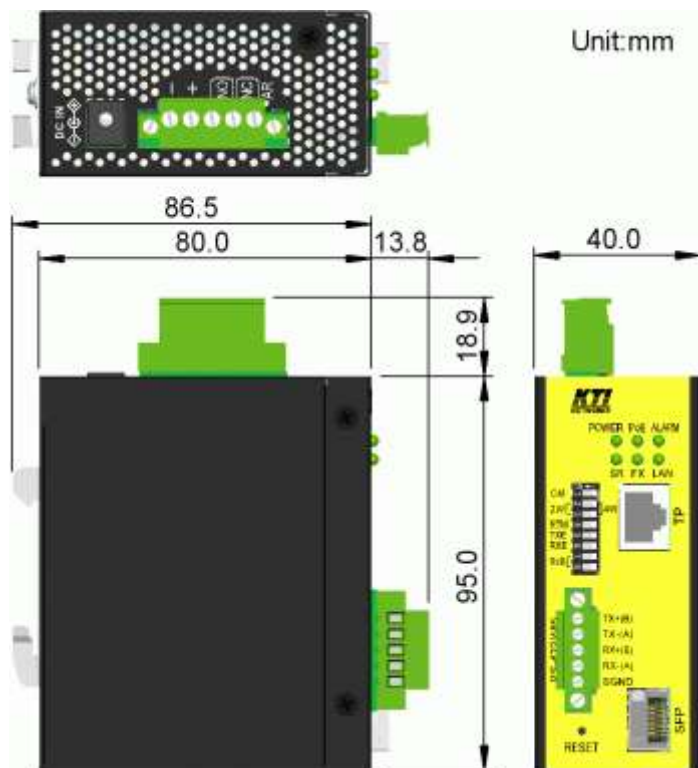

## 2.4 Panel Mounting

The devices are provided with an optional panel mounting bracket. The bracket supports mounting the switch on a plane surface securely. The mounting steps are:

1. Install the mounting bracket on the switch unit.

**KSC-361-S2 (RS-232 model)**

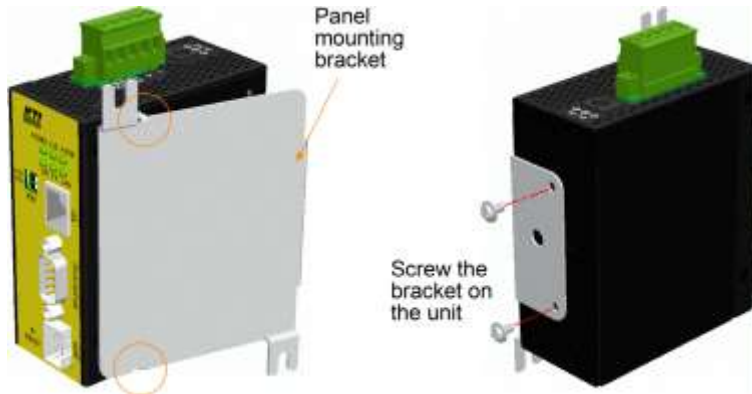

**KSC-361-S4 (RS-422/485 model)**

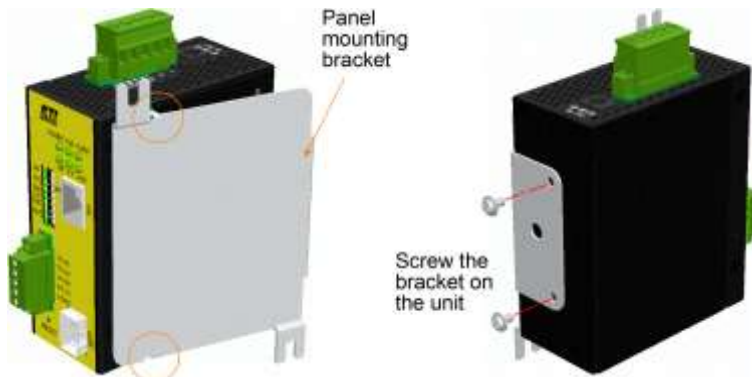

2. Screw the bracket on the switch unit.
3. Screw the device on a panel. Two screw locations (red cross) are shown below:

**KSC-361-S2 (RS-232 model)**    **KSC-361-S4 (RS-422/485 model)**

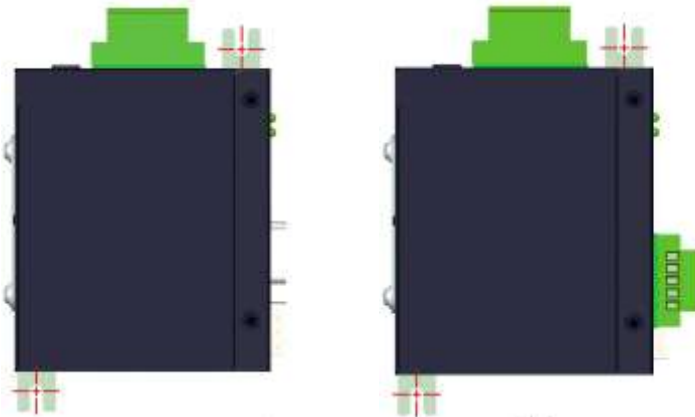

**Dimensions:**

**KSC-361-S2 (RS-232 model)**

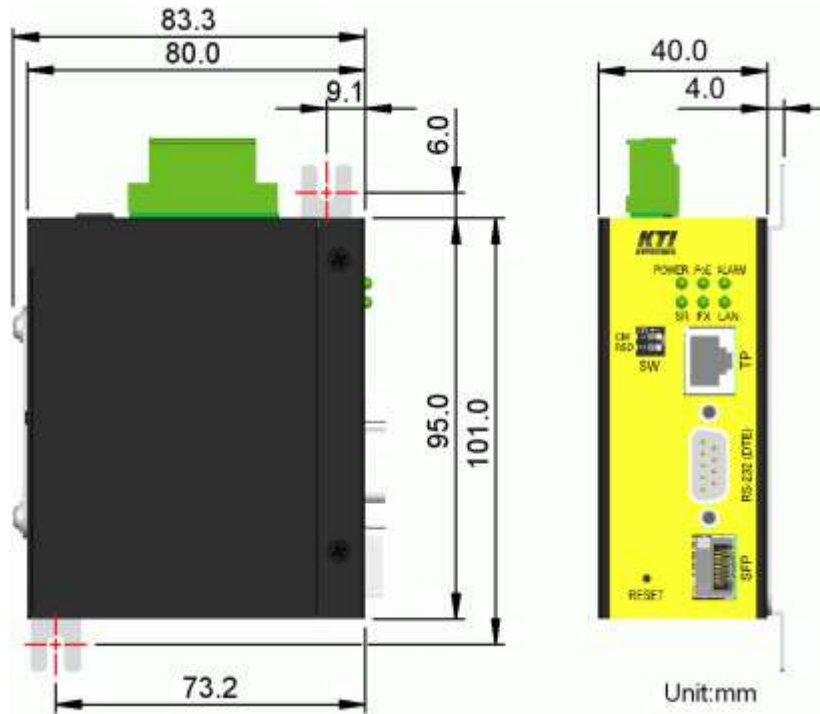

**KSC-361-S4 (RS-422/485 model)**

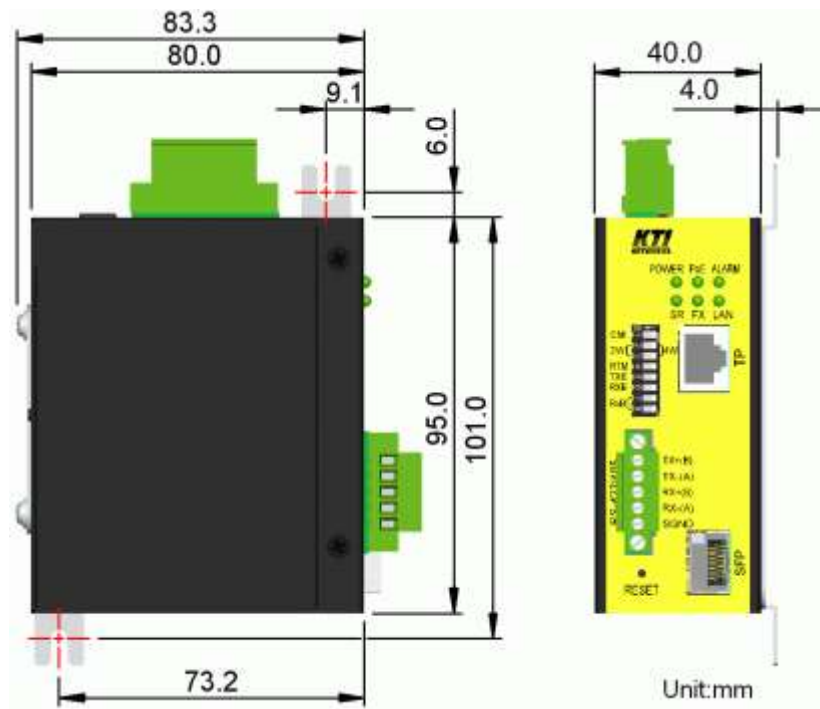

## 2.5 Applying Power

The devices can support three different power input types. Use only one for your installation.

### Power input types

Type	Connector	Voltage input rating	Connect
Terminal block	TB Pin 1, 2	+8VDC ~ +60VDC	External DC power supply
Power Jack	DC Jack	+8VDC ~ +30VDC	External AC-DC power adapter
PoE	RJ-45	+36VDC ~ +57VDC	Remote PoE PSE device over Cat.5

### **Caution:**

*Do not use more than one power input type at the same time. Two power inputs will cause damage to the device. Use just one among the three power inputs for your installation.*

### 2.5.1 Direct Power via Terminal Block

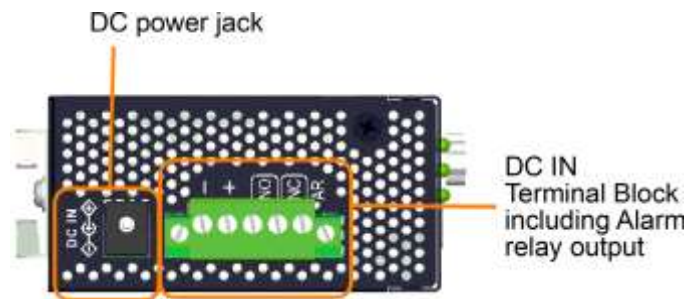

### Power pins of the terminal block connector

Pin	1	-	Vdc negative (-) input terminal
	2	+	Vdc positive (+) input terminal

A 5P terminal plug is provided together with the device as shown below:



Power wires : 24 ~ 12AWG (IEC 0.5~2.5mm<sup>2</sup>), 1 meter max.

## 2.5.2 Direct Power via DC Power Jack

Find an external AC-DC power adapter that can match the following specifications.

### Specifications

Polarity: center positive



Center contact: 2.0mm

Outer contact: 6.3mm

Voltage rating: +8 ~ +30VDC

Note that most of the AC-DC power adapters in the market are provided for commercial use generally. Check the environment conditions before use it. Contact your dealers for the availability of industrial rated power adapter.

### 2.5.3 PoE via RJ-45

The Ethernet RJ-45 port supports PoE connection for receiving power over Cat.5 cable.

The specifications are:

- IEEE 802.3af compliant PD
- Type 1 Class 3 PD
- Input voltage range: +36V ~ +57V
- Pins to receive power:
  - $V_{poe+}$ : Pin 1, 2, 4, 5
  - $V_{poe-}$ : Pin 3, 6, 7, 8

#### Connect PoE mid-span injector over Cat.5 cable

The following figure uses RS-232 model as example. The same connection can be for RS-422/485 model too.

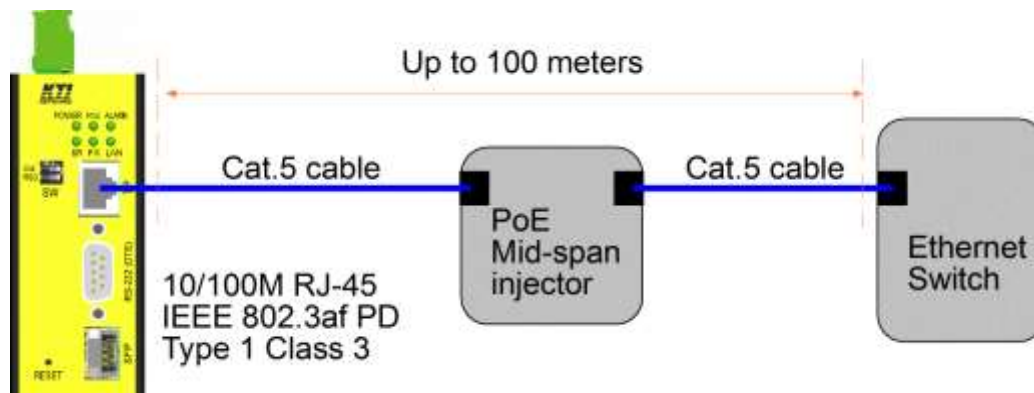

#### Connect PoE end-span PSE Ethernet switch port

The following figure uses RS-232 model as example. The same connection can be for RS-422/485 model too.

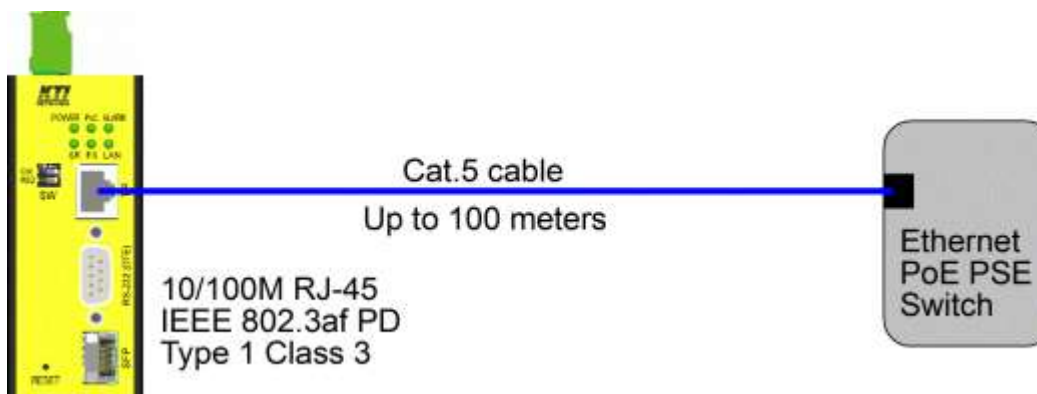

## 2.6 Alarm Relay Output

Alarm relay output is provided for reporting failure events to a remote alarm relay monitoring system. The relay output is provided with three contacts (support two logic types) in the terminal block connector next to Vdc interfaces.

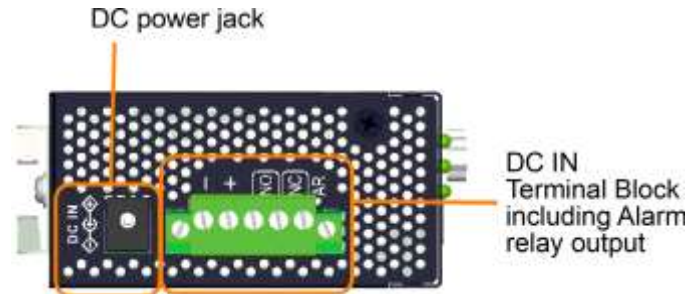

### Alarm Relay output pins and logic:

Pin	3	4	Alarm relay output, NO (Normal Open) contacts
	NO	NO	Open: Normal, Shorted: Alarm
Pin	4	5	Alarm relay output, NC (Normal Closed) contacts
	NC	NC	Shorted: Normal, Open: Alarm

Either pair can be used depending on the logic requirement for the relay monitoring system. Use the provided 3P terminal plug for signal wiring and plug into the contacts.

### Alarm Events

- Input power failure
- Ethernet port link down (Enabled by software.)
- Failure in connecting to server (Enabled by software)

*Note: Be sure the voltage applied on the contacts is within the specification of 30VDC/1A max. or 120VAC/0.5A max.*

## 2.7 Reset Button

The reset button is used to perform a reset to the device. It is not used in normal cases and can be used for diagnostic purpose. If any network hanging problem is suspected, it is useful to push the button to reset the device without turning off the power. Check whether the network is recovered.

The button can also be used to restore the software configuration settings to factory default values.

The operations are:

<b>Operation</b>	<b>Function</b>
Press the button and release when ALARM LED blinking. ALARM LED is blinking until boot-up finished. ALARM becomes OFF.	Reset & boot up the device. The behavior is same as power boot procedure.
Press the button until ALARM LED becomes OFF.	Boot & restore all factory default settings



## 2.8 Making RJ-45 Port Connections

The 10/100 RJ-45 Ethernet copper port supports the following connection types and distances:

### Network Cables

10BASE-T: 2-pair UTP Cat. 3, 4, 5 , EIA/TIA-568B 100-ohm

100BASE-TX: 2-pair UTP Cat. 5, EIA/TIA-568B 100-ohm

Link distance: Up to 100 meters for all above

### Auto MDI/MDI-X Function

This function allows the port to auto-detect the twisted-pair signals and adapts itself to form a valid MDI to MDI-X connection with the remote connected device automatically. No matter a straight through cable or crossover cable connected, the port can sense the receiving pair automatically and configure itself to match the rule for MDI to MDI-X connection. It simplifies the cable installation.

### Auto-negotiation Function

The port is featured with auto-negotiation function and full capability to support connection to any Ethernet devices. The port performs a negotiation process for the speed and duplex configuration with the connected device automatically when each time a link is being established. If the connected device is also auto-negotiation capable, both devices will come out the best configuration after negotiation process. If the connected device is incapable in auto-negotiation, the port will sense the speed and use half duplex for the connection.

## 2.9 Making SFP Fiber Connection

The SFP slot must be installed with an SFP fiber transceiver for making fiber connection.

### **Type of the SFP Fiber transceivers supported:**

100Mbps based 100BASE-FX SFP transceivers

### **Installing SFP Fiber Transceiver**

To install an SFP fiber transceiver into SFP slot, the steps are:

1. Turn off the power to the device.
2. Insert the SFP fiber transceiver into the SFP slot. Normally, a bail is provided for every SFP transceiver. Hold the bail and make insertion.
3. Until the SFP transceiver is seated securely in the slot, place the bail in lock position.

### **Connecting Fiber Cables**

LC connectors are commonly equipped on most SFP transceivers. Identify TX and RX connector before making cable connection. Make sure the Rx-to-Tx connection rule is followed on the both ends of the fiber cable.

### **Network Cables**

Multimode (MMF) - 50/125, 62.5/125

Single mode (SMF) - 9/125

### **Port Configuration**

100Mbps

Full duplex

No auto-negotiation

## 2.10 Selection of Copper RJ-45 or Fiber SFP

The Ethernet port of the device supports either copper RJ-45 connection over Cat.5 or SFP over fiber cable. The selection of RJ-45 or SFP can be configured through web and console configuration. Three configuration options are:

<b>AUTO</b>	Factory default setting SFP is selected if SFP has transceiver installed RJ-45 is selected if SFP has no transceiver installed
<b>RJ-45</b>	RJ-45 is selected always.
<b>SFP</b>	SFP is selected always.

Change of this configuration will be effective in next boot-up.

## 2.11 Setting DIP Switches

KSC-361-S2 (RS-232 model)

SW	Name	Setting	Function
1	CM	ON	Serial port serves console configuration.
		OFF	Serial port serves standard functions.
2	RSD	-	Reserved

KSC-361-S4 (RS-422/485 model)

SW	Name	Setting	Function
1	CM	ON	Serial port serves console configuration.
		OFF	Serial port serves standard functions.
2	2W-4W	ON	2-wire bus,( TX+(B) connects RX+(B) internally )
		OFF	4-wire bus
3	2W-4W	ON	2-wire bus,( TX-(A) connects RX-(A) internally )
		OFF	4-wire bus
4	RTM	ON	Receiver terminator is ON.
		OFF	Receiver terminator is OFF.
5	TXE	ON	Transmitter is enabled always. (serving as the master node in a multi-drop network)
		OFF	Transmitter is controlled by ADC.
6	RXE	ON	Receiver is enabled always. (serving as a slave node in a multi-drop network)
		OFF	Receiver is controlled by ADC.

7	RX-B1	ON	RX+ line bias is ON.
		OFF	RX+ line bias is OFF.
8	RX-B2	ON	RX- line bias is ON.
		OFF	RX- line bias is OFF.

### 2.11.1 4-Wire/2-Wire Bus

[2W] setting activates the internal connection between driver and receiver in RS-422/485 interface. It simplifies the installation of the converter in a 2-wire bus. RS-422 usually uses 2-wire topology only. RS-485 supports both 2-wire and 4-wire topology.

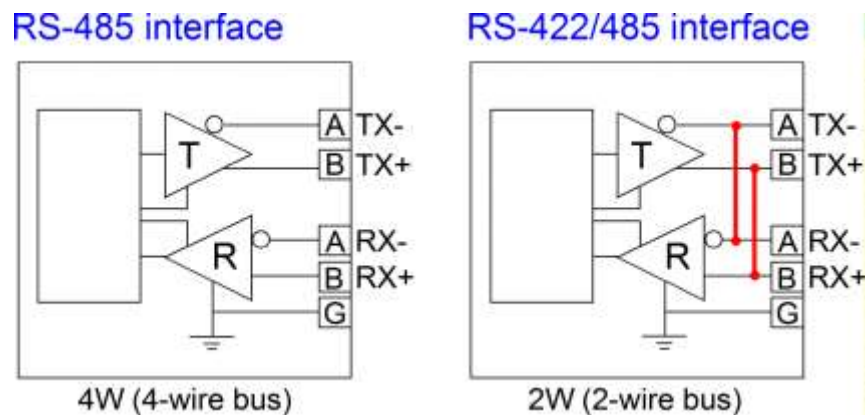

Refer to Appendix for more information about RS-422 / RS-485 standards and 2-wire / 4-wire topology.

### 2.11.2 Receiver Terminator

[RTM] ON setting enables the internal 120 ohms terminator on the receiver interface. A proper termination is important in a bus topology or multi-drop network. The terminator is a resistor added in parallel with the receiver's "A" and "B" lines in order to match the data line characteristic impedance and reduce signal reflection. This setting is useful when the device is installed at the end of a RS-485 or RS-422 bus.

## RS-422/485 interface

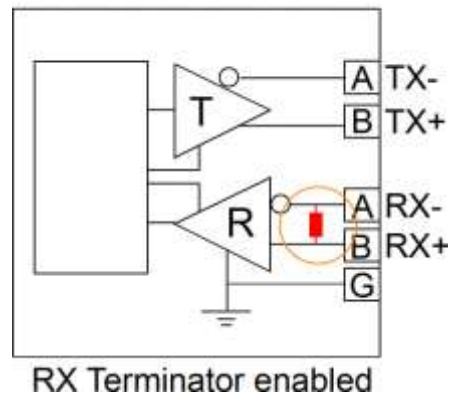

If the internal 120 Ohm terminator is not appropriate for your application, set [RTM] OFF to disable it and use an external one.

### 2.11.3 ADC

ADC method involves special circuitry that senses when data is being transmitted and automatically enables the RS-422/485 driver as well as disabling the receiver within one data byte length till the end of transmission. This is a useful method for driver control since it needs no software involved.

## RS-422/485 interface

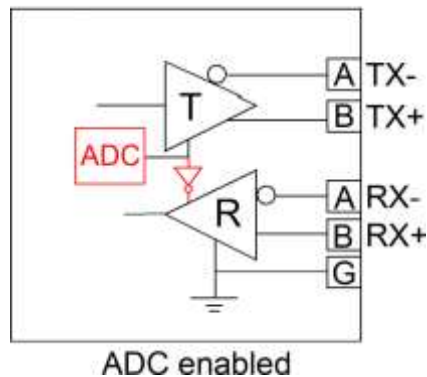

### 2.11.4 Line Bias

The line bias is used to maintain the proper idle-state voltage to the idle condition (when no driver is enabled on the bus). These bias resistors are pull-up resistors on the data B line and pull-down resistors (to ground) on data A line. In 4-wire configuration, the bias resistors are placed on the receiver lines. [RX-B1/B2] OFF disables the internal BIAS resistors on receiver lines. [RX-B1/B2] ON setting enables internal bias resistors. The bias configuration can support up to 30 receiver nodes with no terminators. If the bias configuration is not proper for your physical topology, set [RX-B1/B2] OFF and use external bias design according to your application.

RS-422/485 interface

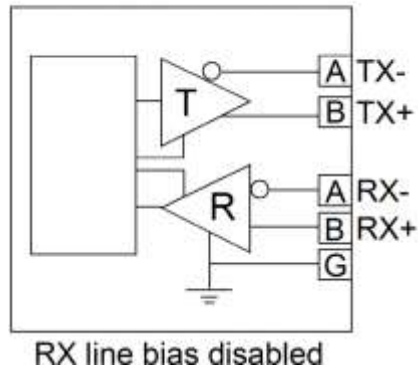

RS-422/485 interface

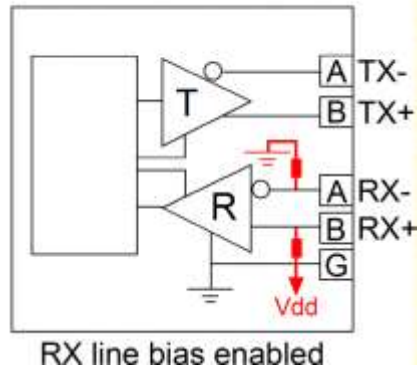

## 2.12 Making RS-232 Connection

RS-232 interface: Male DB9, DTE

The connection is illustrated as follows:

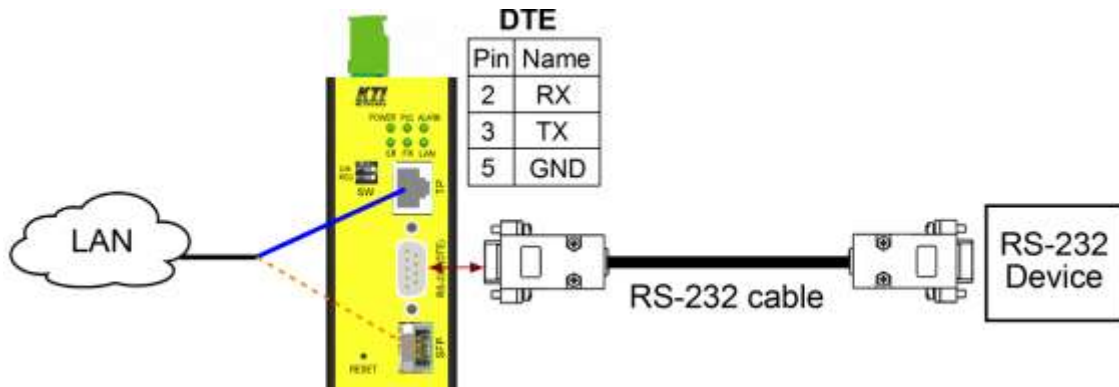

### 2.12.1 Making PC Connection via COM Port

Device's RS-232 interface: Male DB9, DTE

PC COM ports: Male DB9, DTE

RS-232 cable: Null modem without handshaking female DB9 to female DB9

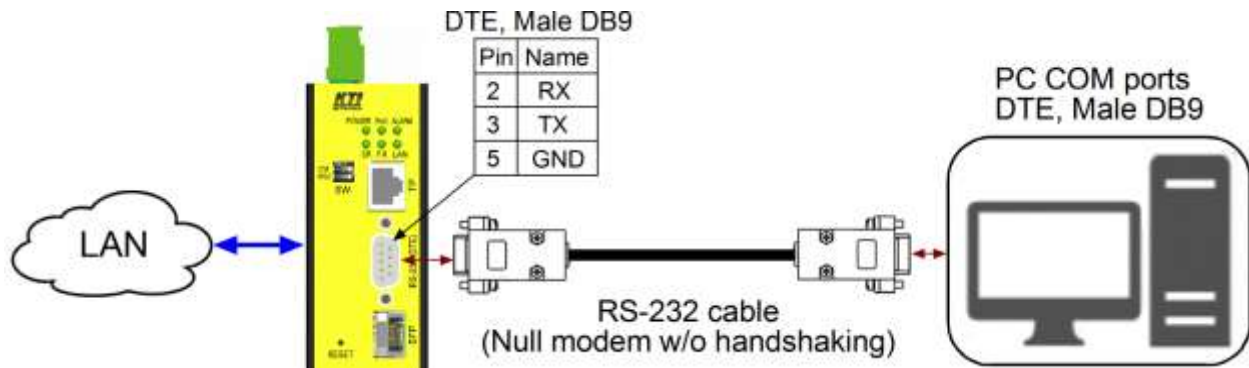

## 2.13 Making RS-422/485 2-Wire Connection

The figure below illustrates the device connects a LAN, via Cat.5 or fiber cable alternatively, and a 2-wire serial bus topology.

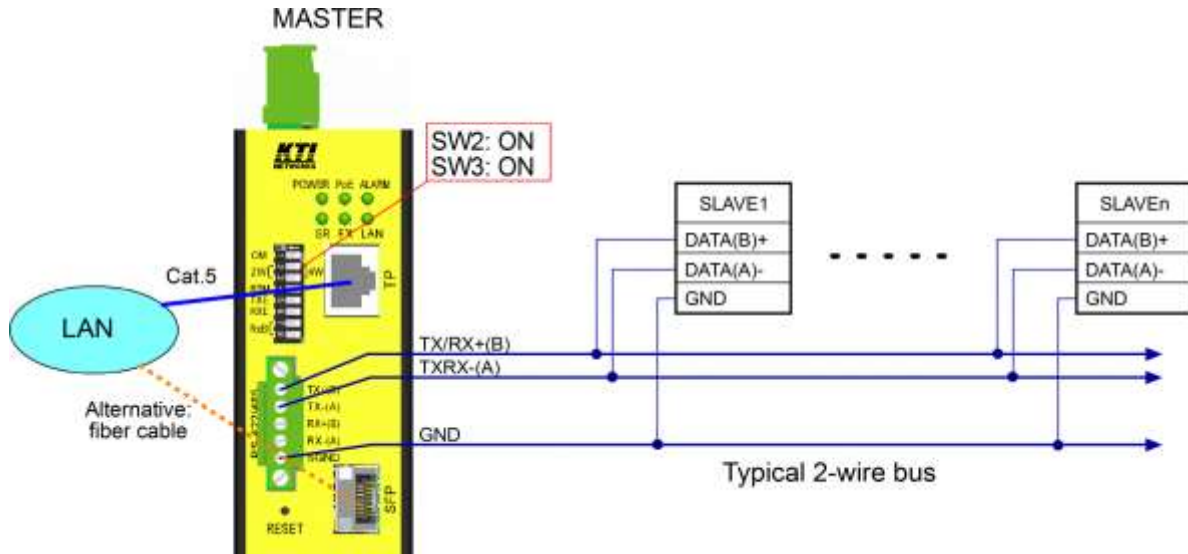

## 2.14 Making RS-485 4-Wire Connection

The figure below illustrates the device connects a LAN, via Cat.5 or fiber cable alternatively, and a 4-wire serial bus topology.

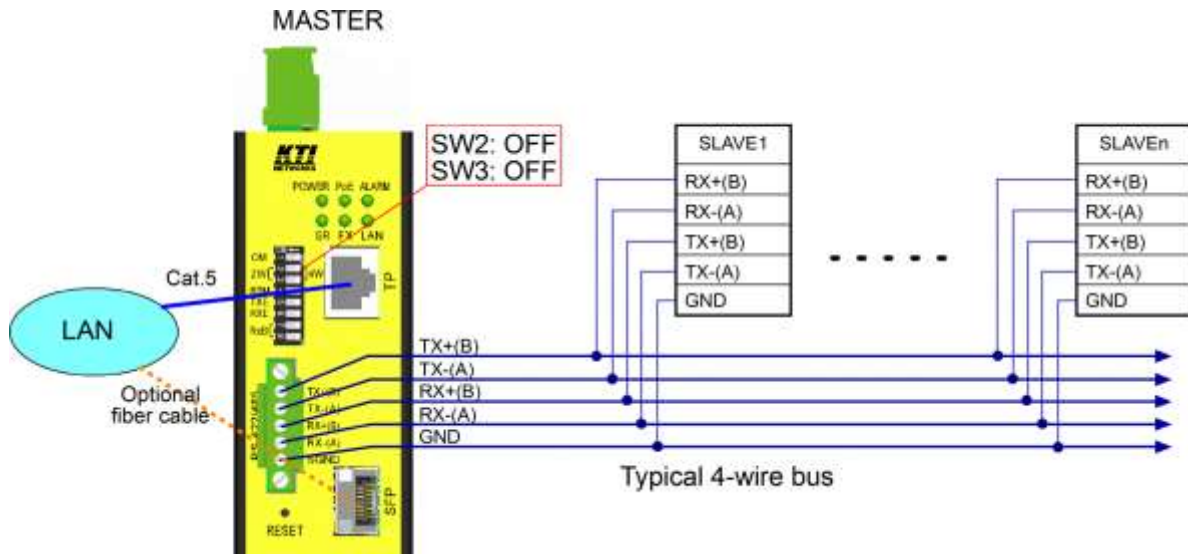

## 2.15 LED Indication

LED	Function	Color	State	Interpretation
POWER	Power status	Green	ON	The power is supplied to the switch.
			OFF	The power is not supplied to the switch.
SR	Serial port activity status	Green	Blink	Tx or Rx on serial port
			OFF	No data traffic
PoE	PoE power status	Green	ON	The device is powered by PoE input.
			OFF	No PoE input
FX	Fiber SFP	Green	ON	SFP is selected and active for Ethernet port
			OFF	SFP is not selected.
ALARM	Alarm status	Green	ON	Alarm event occurred.
			Blink	When the device boot-up
			OFF	No alarm event
LAN	Ethernet port status	Green	ON	Port link up & no traffic
			Blink	Port activity
			OFF	Port link down



## 3. Application Modes

### 3.1 Remote COM Mode

The converter can serve like a local COM port of a Windows PC virtually over LAN. The connection is illustrated as follows:

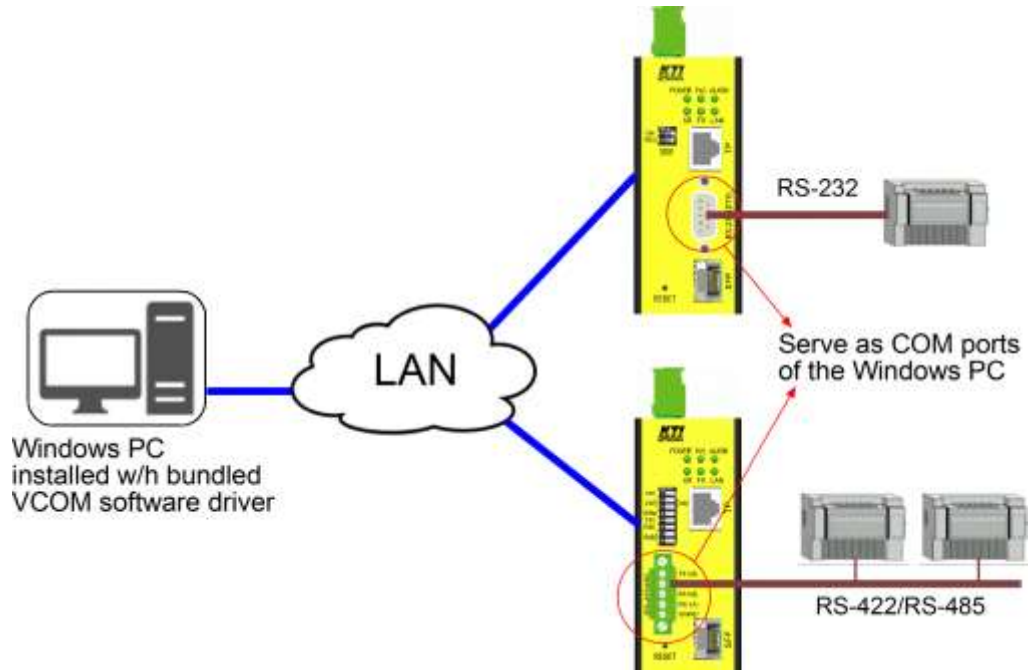

The serial interface can be RS-232 or RS-422/485 bus which more serial devices are connected depending on the product model is used.

To enable this application model, the Windows PC must be installed with a software program called VCOM, which is bundled in the product package's CD. Refer to Appendix 2 for more information.

### 3.2 Pair Connection Mode

Two converters are connected over a LAN and support two serial devices communicate over a LAN remotely.

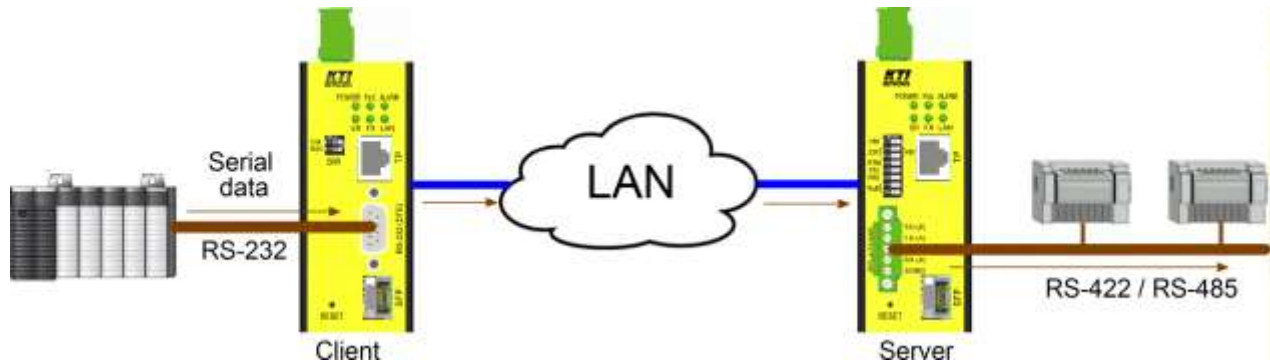

### 3.3 Serial Server Mode

The converter is featured with a mode which the device operates as a serial server. Under this mode, the device forwards the serial data stream received from a client over TCP/IP network to the serial interface.

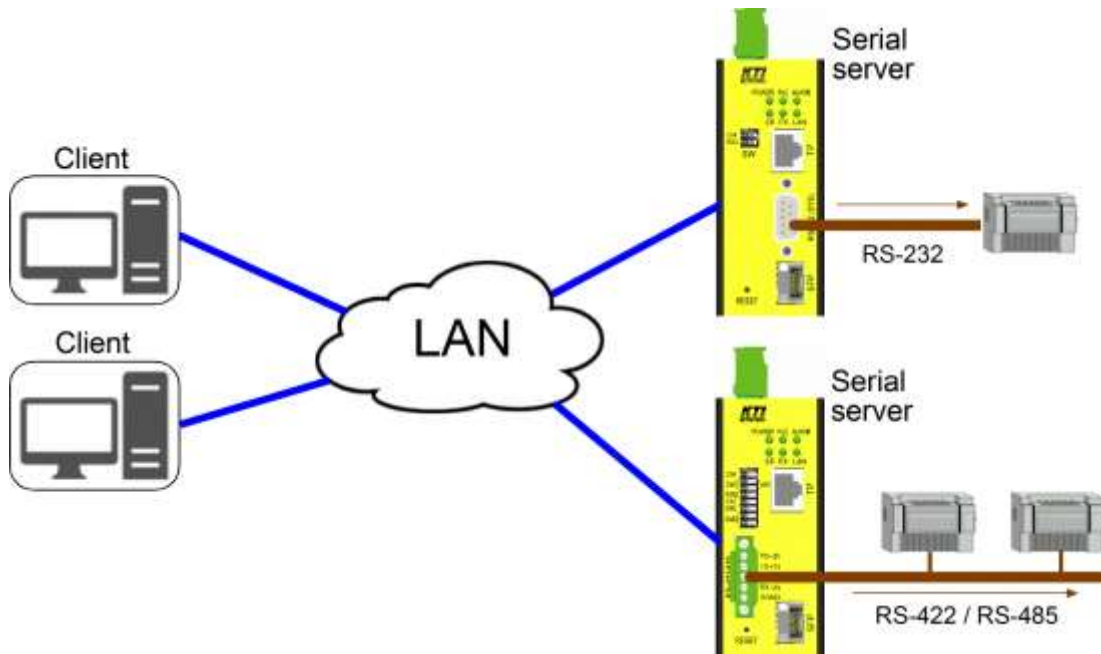

### 3.4 Serial Broadcasting Mode

Under this operating mode, one converter serves “Master” and more than one converter serve “Slave”. The master can broadcast serial data received from serial port to all slave converters via UDP over IP network. The number of slave converters can be up to 10.

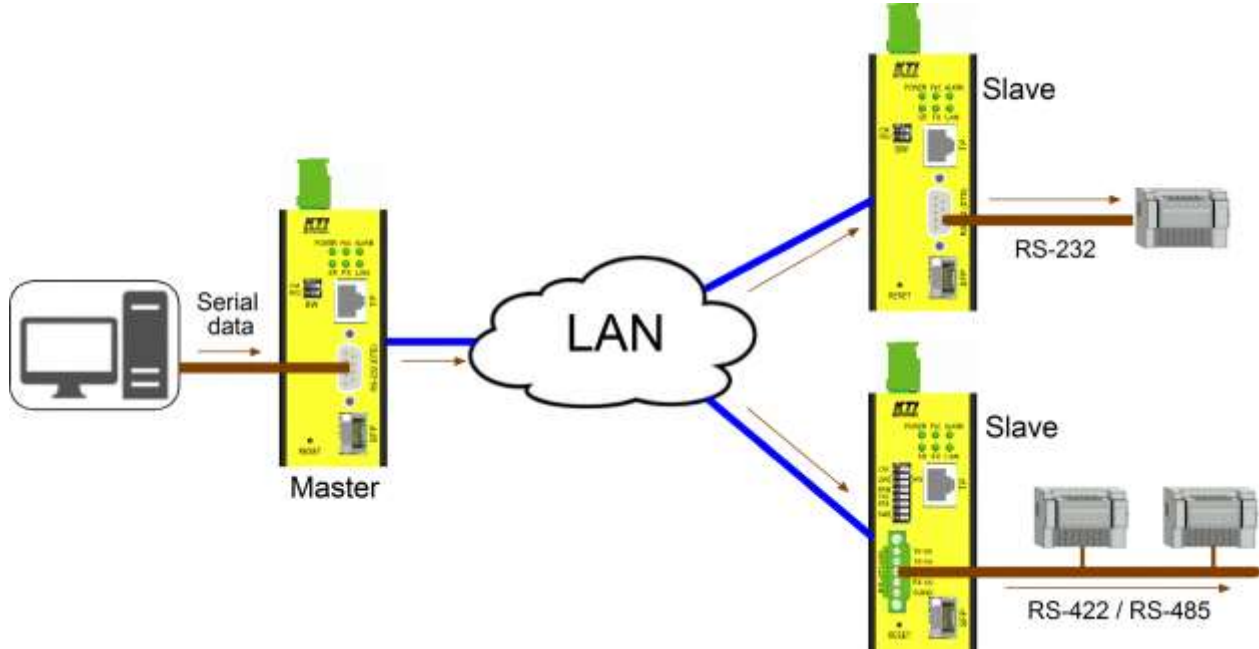

### 3.5 Reverse Telnet Mode

The converter's reverse telnet mode allows a PC host to access another device's console port (serial port) through the converter remotely over a network as illustrated below. The device may be a modem, LAN switch, a router or any with AUX port. Telnet is initiated from the PC and the converter operates as a server for the telnet connection. It forwards the data between PC and the device's console port.

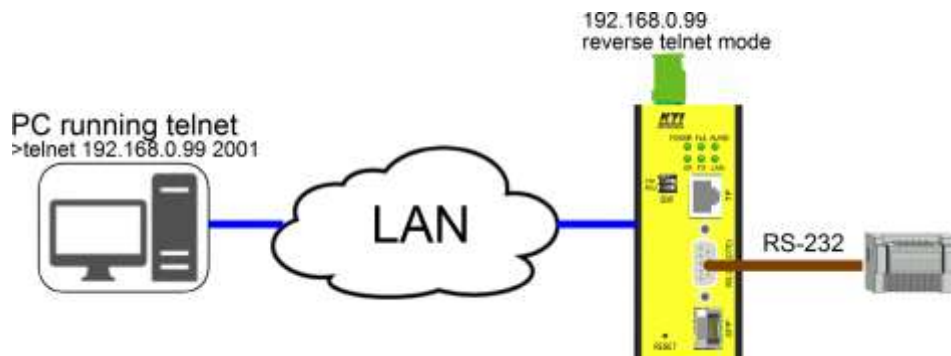

## 4. Configuring IP Address & Password

---

The converter supports the following methods to configure the device as follows:

- Use CLI via the console mode of the serial port (SW [CM] setting ON)
- Use web interface over TCP/IP network via LAN port

### 4.1 IP Address & Password

The IP Address is an identification of the device in a TCP/IP network. Each device should be designated a new and unique IP address in the network. The converter is shipped with the following factory default settings for software management:

Default IP address of the switch: *192.168.0.2 / 255.255.255.0*

Default password: 123

The converter uses local authentication with factory defaults.

The password is required for local authentication in accessing to the device via Http web-based interface. For security reason, it is recommended to change the default settings for the device before deploying it to your network.

### 4.2 Configuring IP Address & Password via console

Setting SW [CM] ON will set the Serial Port to Console Mode for configuration.

The configuration commands are:

*at+set sys name=?*

*at+set sys password=?*

*at+set sys ip address=?*

*at+set sys subnet mask=?*

*at+set sys gateway=?*

*at+set sys dns server=?*

Refer to “Operation manual for telnet and console management”.

### 4.3 Configuring IP Address via Web Interface

#### Start Web Browser

Start your browser software and enter the default IP address of the switch unit to which you want to connect.

The IP address is used as URL for the browser software to search the device.

URL: <http://192.168.0.2/>

### Login to the device

When browser software connects to the device successfully, a Login page is provided for you to login to the device as below:

User's Login	
Site:	192.168.0.177
Password:	●●●

Enter password in the login page:

Default password: 123.

Click  to login into the converter.

### Web Page after a Successful Login

System Host Configuration	
MAC Address	00-40-F8-D1-00-00
Software Version	v1.00_beta_2017072413
Hardware Version	v1.00
Name	KSC-361_0040F6D10000 Max: 20C
Password	●●●
Confirm Password	●●● Max: 15C
IP Address	192 168 0 188
Subnet Mask	255 255 255 0
Default Gateway	192 168 0 1
DNS Server	192 168 0 1
IP Configuration Mode	<input checked="" type="radio"/> Static <input type="radio"/> DHCP
LAN Port Media Type	Auto
Alarm Relay	LAN Port Link Down <input type="checkbox"/>
	Failure in connecting to server <input type="checkbox"/>

Use [System Host] page to configure IP address and password for the device.

Click  to save the configuration changes.

Use [Reboot System] command to reboot the device and make the changes effective.

Refer to Chapter5 Web Management for the details.

# 5. Web Management

---

## 5.1 Login

User's Login	
Site:	192.168.0.177
Password:	<input type="password" value="•••"/>

Factory default password: 123

Note that the user is requested to make a login again when the inactivity timeout, 10 minutes is expired with no user's operation in Web UI.

## 5.2 Main Menu

<b>Configuration</b>
System Host TCP Control UDP Control Serial Port Control
<b>Notification</b>
Email and SNMP Trap Events
<b>Monitoring</b>
Statistics Overview
<b>Diagnostics</b>
Ping
<b>Maintenance</b>
Reboot System Restore Default Update Firmware Logout

## 5.3 System Host Configuration

This page is used to show device information and configure the basic operating settings for authentication, IP address, LAN port and Alarm relay.

### System Host Configuration

MAC Address	00-40-F6-D1-00-00			
Software Version	v1.00_beta_2017072413			
Hardware Version	v1.00			
Name	KSC-361_0040F6D10000 Max: 20C			
Password	●●●			
Confirm Password	●●●		Max: 15C	
IP Address	192	168	0	188
Subnet Mask	255	255	255	0
Default Gateway	192	168	0	1
DNS Server	192	168	0	1
IP Configuration Mode	<input checked="" type="radio"/> Static <input type="radio"/> DHCP			
LAN Port Media Type	Auto ▼			
Alarm Relay	LAN Port Link Down	<input type="checkbox"/>		
	Failure in connecting to server	<input type="checkbox"/>		

Apply

Configuration	Description
MAC Address	Ethernet MAC address of the device
Software Version	The revision number of the embedded firmware currently operating
Hardware Version	The hardware version of the device
Name	Name, as a logical identification, designated to this device
Password	Password setting for Login authentication
Confirm Password	Re-enter the password if it is changed.
IP Address	The IP address designated to this device when static IP mode is used.
Subnet Mask	The IP subnet mask of this device
Default Gateway	The IP address of the default gateway used by this device
DNS Server	The IP address of the DNS server used by this device
IP Configuration Mode	<i>Static</i> – Fixed IP mode <i>DHCP</i> – Dynamic IP assigned by DHCP server
LAN Port Media Type	<i>Auto</i> – Auto detection for media, Use FX if an SFP transceiver is installed in slot,

otherwise TP is used

TP – RJ-45 copper

FX – SFP fiber

Alarm Relay Alarm relay output when any of the configured events occurs

LAN port link down Check to enable it as an alarm relay event.

Failure in connecting to server Check to enable it as an alarm relay event.

---

Apply	Click to save the changes.
-------	----------------------------

---

**Important Note:**

*The changes become effective in next device's boot-up. You may use [Reboot System] command to reboot the device or power off and power on the device.*

## 5.4 Application Configuration

The Web UI provides simplified configuration for different applications as follows:

Application	Number of converter devices involved	TCP/UDP Configuration
Pair Connection	One TCP server device One TCP client device.	Use TCP Control
Serial Server	One TCP server device as the serial server One TCP client device.	Use TCP Control
Remote COM	One TCP server device Windows PC installed with VCOM as TCP client	Use TCP Control
Serial Broadcasting	One UDP master device One or more (up to 10) UDP slave devices	Use UDP Control
Reverse Telnet	One TCP server device PC host running telnet as a client	Use TCP Control
Advanced	Allow the maximum flexibility for application configuration with no pre-settings and no foolproof	Free configuration dependent on specific application

*Remark:*

*TCP server device: A converter operating in TCP server mode*

*TCP client device: A converter operating in TCP client mode*

*UDP master device: A converter operating in UDP mode and enabled to broadcast serial stream*

*UDP slave device: A converter operating in UDP mode and enabled to receive serial stream from master*

Refer to Chapter 3 for illustrations of the listed applications.



## 5.5 TCP Control Configuration

This is used to set the device operating as TCP server or TCP client in application.

### TCP Server

#### TCP Control Configuration

Application	Advanced <input type="button" value="Change"/>
Operation Mode	<input checked="" type="radio"/> Server <input type="radio"/> Client <input type="radio"/> Disable
Data Port Number	6001 (1~65535)
Remote Server	<input checked="" type="radio"/> IP 192 . 168 . 0 . 1 <input type="radio"/> Domain Name 0
Client Keep Connected	<input checked="" type="checkbox"/> Keep Connected
Client Keep Alive Time	0 seconds (1~255,0: disable)
Server Alive Time	0 minutes (1~99,0: disable)

### TCP Client

#### TCP Control Configuration

Application	Advanced <input type="button" value="Change"/>
Operation Mode	<input type="radio"/> Server <input checked="" type="radio"/> Client <input type="radio"/> Disable
Data Port Number	6001 (1~65535)
Remote Server	<input checked="" type="radio"/> IP 192 . 168 . 0 . 1 <input type="radio"/> Domain Name 0
Client Keep Connected	<input checked="" type="checkbox"/> Keep Connected
Client Keep Alive Time	0 seconds (1~255,0: disable)
Server Alive Time	0 minutes (1~99,0: disable)

---

#### Configuration

#### Description

---

Application	Select a matched application if you need a simplified configuration.
Operating Mode	<i>Server</i> – This converter will operate as a TCP server. <i>Client</i> – This converter will operate as a TCP client. <i>Disable</i> – TCP communication is disabled.
Remote Server	The IP address of the remote server to which this client is planned to connect. (Client's setting)
Domain Name	Domain name is allowed if the exact IP address of the remote server is unknown.
Client Keep Connected	Check to enable the client to call a re-connection every second if a connection failed.

(Client's setting)

Client Keep Alive Time The client sends "keep-alive" message to the remote server in a period of this time setting when it is in idle state. (Client's setting). The message can notify the remote server that the client is still alive and just in idle state.

Server Alive Time TCP connection is closed if there is no TCP activity in the given time duration. Keep-alive message will reset the time count. (Server's setting)

---

Click to save the changes.

---

## 5.5.1 Selecting Application Mode

For easy configuration, you may select an application mode that matches your application exactly. The web UI will give minimum settings required for the selected application.

### Application Mode Configuration

Serial Broadcast ▼

Apply

The applications provided are:

- Pair Connection
- Serial Server
- Remote COM
- Serial Broadcast
- Reverse Telnet

### Application Mode Configuration

Advanced ▼  
Advanced  
Pair Connection  
Serial Server  
Remote COM  
Serial Broadcast  
Reverse Telnet

figuration, select the mode that matches your application.  
ts full configuration options.

Refer to Chapter 3 for description of each application mode.

## 5.6 UDP Control Configuration

This configuration is used only for “Serial Broadcasting” application mode. There are Master device and Slave devices involved in this application. Each is provided with different configuration interface as shown in following two sections.

### 5.6.1 UDP Master Configuration

#### UDP Control Configuration

Application	Serial Broadcast <input type="button" value="Change"/>	
Operation Mode	<input type="radio"/> Slave <input checked="" type="radio"/> Master <input type="radio"/> Disable	
Local Port Number	21	
	<input checked="" type="radio"/> 0 . 0 . 0 . 0 IP <input type="radio"/> 0 Domain Name	Port Number 0
	<input checked="" type="radio"/> 0 . 0 . 0 . 0 IP <input type="radio"/> 0 Domain Name	Port Number 0
	<input checked="" type="radio"/> 0 . 0 . 0 . 0 IP <input type="radio"/> 0 Domain Name	Port Number 0

Remote Slave	<input checked="" type="radio"/> 0 . 0 . 0 . 0 IP <input type="radio"/> 0 Domain Name	Port Number 0
	<input checked="" type="radio"/> 0 . 0 . 0 . 0 IP <input type="radio"/> 0 Domain Name	Port Number 0
	<input checked="" type="radio"/> 0 . 0 . 0 . 0 IP <input type="radio"/> 0 Domain Name	Port Number 0
	<input checked="" type="radio"/> 0 . 0 . 0 . 0 IP <input type="radio"/> 0 Domain Name	Port Number 0
	<input checked="" type="radio"/> 0 . 0 . 0 . 0 IP <input type="radio"/> 0 Domain Name	Port Number 0
	<input checked="" type="radio"/> 0 . 0 . 0 . 0 IP <input type="radio"/> 0 Domain Name	Port Number 0
	<input checked="" type="radio"/> 0 . 0 . 0 . 0 IP <input type="radio"/> 0 Domain Name	Port Number 0

#### Configuration

#### Description

Application

Change another matched application if you need a simplified configuration.

Operation Mode	<i>Master</i> – The master sends received serial data stream to all slave devices over UDP. <i>Slave</i> – The slave receives the UDP data sent by the master and forwards it to its serial port. <i>Disable</i> – no UDP configuration
Local Port Number	The port number used by the master to receive data over UDP
Remote Slaves	Configuration of the target slave devices
Slave IP	IP address of each individual slave device
Slave Domain Name	Domain name of each individual slave device
Slave Port Number	UDP port number to which the master sends data to the slave over UDP

---

**Apply** Click to save the changes.

---

*Note: The changes will be effective after next device's boot-up.*

## 5.6.2 UDP Slave Configuration

### UDP Control Configuration

Application	Serial Broadcast	<input type="button" value="Change"/>
Operation Mode	<input checked="" type="radio"/> Slave <input type="radio"/> Master <input type="radio"/> Disable	
Local Port Number	21	
	<input checked="" type="radio"/> 0 . 0 . 0 . 0 IP <input type="radio"/> 0 Domain Name	Port Number 0
	<input checked="" type="radio"/> 0 . 0 . 0 . 0 IP <input type="radio"/> 0 Domain Name	Port Number 0
	<input checked="" type="radio"/> 0 . 0 . 0 . 0 IP <input type="radio"/> 0 Domain Name	Port Number 0
	<input checked="" type="radio"/> 0 . 0 . 0 . 0 IP <input type="radio"/> 0 Domain Name	Port Number 0

---

Configuration	Description
Application	Change another matched application if you need a simplified configuration.
Operation Mode	<i>Master</i> – The master sends received serial data stream to all slave devices over UDP. <i>Slave</i> – The slave receives the UDP data sent by the master and forwards it to its serial port.
Local Port Number	The port number used to receive data from the master over UDP communication

---

**Apply** Click to save the changes.

---

*Note: The changes will be effective after next device's boot-up.*

## 5.7 Serial Port Control Configuration

This web UI is used to configure the parameters for the serial interface. The configuration also includes the control rules used in operation of forwarding received data from serial port to LAN port.

### Serial Port Control Configuration

Baudrate	230400 ▼		
Data Bits	8 ▼		
Parity Bits	none ▼		
Stop Bits	1 ▼		
Packing Rules	Packing Size	0 (1~1024 bytes, 0: no limit)	
	In-Queue Time	0 (0~255, 0: disable)*20ms	
	Delimiter	Del	▼
		<input type="checkbox"/> Del-Code 1	AA (Hex)
<input type="checkbox"/> Del-Code 2	BB (Hex)		

Apply

Configuration	Description
Baudrate	The data rate configured by the serial port, <i>Options: 300, 1200, 2400, 4800, 9600, 19200, 38400, 57600, 115200, 230400</i> <i>(Default)</i>
Data Bits	The data length configured for the serial port, <i>Options: 8 (Default), 7</i>
Parity Bits	The parity bits configured for the serial port, <i>Options: none (Default), even, odd, space, mark</i> <i>mark</i> - the parity bit is asserted. <i>space</i> - the parity bit is un-asserted.
Stop Bits	The stop bits configured for the serial port, <i>Options: 1 (Default), 1.5 (for data 5 bits) or 2</i>
Packing Rules	Any data received from the serial port will be stored in an RX queue first before it is forwarded to LAN port. The packing rules are used in operation how the packed data in RX queue is forwarded to LAN port.
Packing Size	The size limit of data received and packed in queue from serial port The packed data is forwarded to LAN port in one Ethernet frame if the data is over the size limit. <i>Options: 0 – no limit (Default), 1 ~ 1024 bytes</i>
In-Queue Time	The time limit that no more data is received in queue from serial port The packed data is forwarded to LAN port when the time limit is expired. <i>Options: 0 – disable (Default), 1 ~ 255 (Unit: 20ms)</i>

**Delimiter Rule** Delimiters are some special data codes embedded in received serial data stream. For example, ASCII code CR (0A<sub>hex</sub>) and LF (0D<sub>hex</sub>) are often used as end of line in serial communication. They are common delimiters. Upon received, the delimiters are used as time indicator to forward the packed data in queue to LAN port in one Ethernet frame

*Options:*

*Del (Default) - forward when delimiters are received*

*Del+1 - forward when one more byte is received after delimiters*

*Del+2 - forward when two more bytes are received after delimiters*

*Del&stripped - forward when delimiters are received but delimiters are removed*

**Del-Code 1** The first delimiter code that is required in selected delimiter rule, *Disabled (Default)*

**Del-Code 2** The second delimiter code that is required in selected delimiter rule, *Disabled (Default)*

---

Click to save the changes.

---

*Note:*

*The packing rules and delimiter rule are examined at the same time upon any data received in serial port. No priority is defined between different rules.*

## 5.8 Event Notification

Some events can be configured with notification when they occur. The notification can be sent via SMTP Email and SNMP trap.

### 5.8.1 Notification via SNMP Trap and Email

#### SNMP Trap

Trap Destination Address	<input type="text"/>
--------------------------	----------------------

#### Mail Server

Simple Mail Transfer Protocol (SMTP)	
Enabled	<input type="checkbox"/>
Port Number	<input type="text" value="25"/>
Server Address	<input type="text" value="ex_smtp_server.hinet.net"/>
Login Information	Authentication <input type="checkbox"/> Yes
	Username <input type="text" value="username"/>
	Password <input type="password" value="••••••"/>
Mail To	<input type="text" value="ex_user1_mail@abc.com.tw;ex_user2_mail@abc.com.tw;"/> Max: 200C
Mail From	<input type="text" value="ex_user_mail@server.com.tw"/>
Communication Test	<input type="button" value="Start"/>

---

Configuration	Description
Trap Destination Address	The destination IP address to which a notification SNMP trap is sent
SMTP	Simple Mail Transfer Protocol complaint Email (No SSL/TLS support)
Enabled	Check to enable Email notification
Port Number	The port number used in SMTP, port 25 is default value.
Server Address	Email server address
Login Information	Login settings for the Email server
Authentication	Is Authentication required?
Username	Username for login
Password	Password for login
Mail To	Email addresses to which the notification mail is sent (200 characters max.)
Mail From	Email addresses from which the notification mail is sent
Communication Test	Click <input type="button" value="Start"/> to test the connection with the Email server.

---



## 5.8.2 Notification Events

### Notification Events

Events	SNMP Trap	Email Server
Cold Start	<input checked="" type="checkbox"/>	<input type="checkbox"/>
Warm Start	<input checked="" type="checkbox"/>	<input type="checkbox"/>
LAN Port Link up	<input type="checkbox"/>	<input type="checkbox"/>
Authentication Failure (Web)	<input type="checkbox"/>	<input type="checkbox"/>
Password Changed	<input type="checkbox"/>	<input type="checkbox"/>
IP Address Change (Include Change to DHCP)	<input type="checkbox"/>	<input type="checkbox"/>
TCP Connection Failed	<input type="checkbox"/>	<input type="checkbox"/>

Configuration	Description
Events	Events that are listed with notification
SNMP Trap	Notification via SNMP trap
Email Server	Notification via SMTP Email
Cold Start	The device is boot-up by power-up.
Warm Start	The device is reboot by web UI command.
LAN Port Link Up	Link up on LAN port
Authentication Failure (Web)	Authentication failed in web login
Password Changed	Authentication password is changed.
IP Address Changed (Include change to DHCP)	IP configuration is changed.
TCP Connection Failed	TCP connection is failed.

Click to save the changes.

## 5.9 Statistic Overview

### Statistics Overview

TCP Connection Status	Connected. Remote IP is 192.168.0.113
Client Connection Failure Count	0

Status	Description
TCP Connection Status	Current state of the TCP connection, the states are: <i>Disconnected</i> <i>Listen</i>

*Connected. Remote IP is xx.xx.xx.xx*

*Wait for Disconnect*

Client Connection Failure Count    Counting the number that TCP client failed to connect TCP server

---

<input type="button" value="Auto Refresh"/>	Click to update the status and counter every three seconds automatically and switch to <input type="button" value="Manual Refresh"/> button.
<input type="button" value="Manual Refresh"/>	Click to stop refreshing the status and counter display and switch to <input type="button" value="Auto Refresh"/> button.
<input type="button" value="Clear"/>	Reset the status and counter.

---

## 5.10 Ping

Ping utility is a helpful tool to troubleshoot problems in an IP network. It is a specific method for sending messages from one device to another as part of troubleshooting IP network connections. A **ping test** determines whether your device can communicate with another device across a network. In cases where network communication is successfully established, ping tests also can determine the connection latency (a technical term for connection delay) between the two devices.

### ICMP Ping

IP Address	0 . 0 . 0 . 0
Ping Length	56
Ping Count	5
Ping Interval	1

Click  to save test parameters for future use.

Click  to start the ping test.

## 5.11 Reboot System

This command is used to reboot, or called warm-start the device. New boot-up will make configuration changes effective. Click  to proceed with the re-boot operation.

### Reboot System

Are you sure you want to reboot system?

## 5.12 Restore Default

This command is used to restore the configuration with factory default settings.

### Restore Default

Are you sure you want to restore factory default?    
( Yes: restore factory default excluding IP and Password configuration )

Click [Yes] to proceed with the operation.

*Note: The settings inside the red square are kept and not changed after this command..*

### System Host Configuration

MAC Address	00-40-F6-D1-00-00			
Software Version	v1.00_beta_2017072413			
Hardware Version	v1.00			
Name	KSC-361_0040F6D10000 Max: 20C			
Password	<input type="password" value="..."/>			
Confirm Password	<input type="password" value="..."/> Max: 15C			
IP Address	<input type="text" value="192"/>	<input type="text" value="168"/>	<input type="text" value="0"/>	<input type="text" value="188"/>
Subnet Mask	<input type="text" value="255"/>	<input type="text" value="255"/>	<input type="text" value="255"/>	<input type="text" value="0"/>
Default Gateway	<input type="text" value="192"/>	<input type="text" value="168"/>	<input type="text" value="0"/>	<input type="text" value="1"/>
DNS Server	<input type="text" value="192"/>	<input type="text" value="168"/>	<input type="text" value="0"/>	<input type="text" value="1"/>
IP Configuration Mode	<input checked="" type="radio"/> Static <input type="radio"/> DHCP			
LAN Port Media Type	Auto ▾			
Alarm Relay	LAN Port Link Down	<input type="checkbox"/>		
	Failure in connecting to server	<input type="checkbox"/>		

## 5.13 Firmware Update

Firmware update operation is divided into several steps as follows:

1. Confirm update request.

### Update Firmware

Are you sure you want to update firmware?

2. Warning message is displayed.



3. Erasing flash (firmware code image) running messages:

Processing update now, please wait...

Erase Flash (32/512)

If this web page doesn't display correctly after operation, try to connect <http://192.168.0.177> .

*Note: <http://192.168.0.177> is just an example. In real case it shows IP address of your device.*

4. Browse and select the firmware image file for uploading after flash is erased completely.



5. Click [Upload] to start image uploading. The message is displayed:

Uploading.....32%

6. When upload completed, OK is displayed and the device starts a reboot. The reboot takes 10 seconds.

OK!



7. Click [Continue] to enter web login page.

OK!

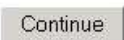

8. Web login page

User's Login	
Site:	192.168.0.177
Password:	<input type="text"/>

*Note:*

*In the case that the device was powered down accidentally during erasing flash, you may turn the device on to let it enter **Step 3** to complete the Erasing flash procedure.*

*In the case that the device was powered down accidentally after erasing flash completed but uploading image not completed, you may turn the device on to let it enter **Step 4** to complete the firmware image uploading procedure.*

## 5.14 Logout

Logout

Are you sure you want to logout ?

Click  to confirm logout.

## 6. Console Commands

---

The serial port can be set to console mode that allows user to enter configuration commands via the serial port instead of in-band web interface.

Set DIP SW1[CM] ON to enable the serial port console mode.

### 6.1 Connecting Console

1. Set console mode of the converter as described in Section 2.11.
2. Connect PC COM port as described in Section 2.12.1.
3. Execute Hyper terminal utility on the PC.
4. Console output system information as below:

```
/*==== KSC-361 Ethernet to Serial Converter ====*/
CPU & PHY Check: OK!!
MAC Address      : 00 40 f6 d1 00 02
DHCP Client     : Disabled
IP Address       : 192.168.0.177
Subnet Mask      : 255.255.255.0
Gateway Address : 192.168.0.1
DNS Address      : 192.168.0.1
LAN Port Media  : Auto
Operation Mode   : TCP server
Serial Port      : Baud Rate 230400 bps
Console Mode     : Enabled
S/W Version      : v1.00 Beta 20170315 pm1610
H/W Version      : v1.00
EEPROM used      : 1339/2048 Byte
/*=====*/
```

5. The console is ready to accept command.

### 6.2 Console Command Sets

#### Command Syntax:

1. Read Configuration

```
at+set cccc=,␣
```

(cccc: command string)

2. Set Configuration

at+set cccc=ssss↵

(cccc: command string, ssss: setting string)

### 3. Direct command

at&cccc ↵

(cccc: command string)

*Note: No command prompt is provided in the console mode.*

### System Host Command Set

Command	Options	Description
at+set sys name= <i>nm</i>	<i>nm</i> – xxxx (20C)	Device name
at+set sys password= <i>pw</i>	<i>pw</i> – xxxx (15C)	Password
at+set sys dhcp= <i>dh</i>	<i>dh</i> – enabled, disabled	DHCP mode
at+set sys ip address= <i>ip</i>	<i>ip</i> - xxx.xxx.xxx.xxx	IP address
at+set sys subnet mask= <i>sm</i>	<i>sm</i> - xxx.xxx.xxx.xxx	Subnet mask
at+set sys gateway= <i>ip</i>	<i>ip</i> - xxx.xxx.xxx.xxx	Default gateway IP
at+set sys dns server= <i>ip</i>	<i>ip</i> - xxx.xxx.xxx.xxx	DNS server IP
at+set sys lpmt= <i>mt</i>	<i>mt</i> - auto, tp, fx	LAN port media type
at+set sys ar lpld= <i>ld</i>	<i>ld</i> - enabled, disabled	Alarm relay event: LAN port link down
at+set sys ar tcp scf= <i>cf</i>	<i>cf</i> - enabled, disabled	Alarm relay event: TCP connection failure

### TCP Control Command Set

Command	Options	Description
at+set application= <i>ap</i>	<i>ap</i> - advanced, pair connection, serial server, remote com, serial broadcast, reverse telnet	Application mode
at+set operation mode= <i>mode</i>	<i>mode</i> - disabled, tcp client, tcp server, udp slave, udp master	Device operation mode
at+ set tcp rs= <i>ss</i>	<i>ss</i> – ip, domain name	Remote server configuration
at+ set tcp rs ip= <i>ip</i>	<i>ip</i> - xxx.xxx.xxx.xxx	Remote server IP
at+ set tcp rs dn= <i>dn</i>	<i>dn</i> – domain name (29 characters)	Remote server domain name
at+ set tcp dpn= <i>pn</i>	<i>pn</i> - 1 ~ 65535	Data port number
at+ set tcp client kc= <i>kc</i>	<i>kc</i> - enabled, disabled	Client keep connected
at+ set tcp client kat= <i>kat</i>	<i>kat</i> - 0 (disabled), 1~255 (unit: 20ms)	Client keep alive time



at+ set tcp server at=at	at - 0 (disabled), 1~99 (unit: minutes)	Server alive time
--------------------------	---	-------------------

### UDP Control Command Set

Command	Options	Description
at+set application=ap	ap - advanced, pair connection, serial server, remote com, serial broadcast, reverse telnet	Application mode
at+set operation mode=om	om - disabled, tcp client, tcp server, udp slave, udp master	Device operation mode
at+ set udp lpn=n	n - 1 ~ 65535	Local port number
at+ set udp rs=ss	ss - ip, domain name	UDP slave configuration
at+ set udp rs ip=ip:n	ip - xxx.xxx.xxx.xxx n - 1 ~ 10 (slave ID)	UDP slave IP
at+ set udp rs dn=d:n	d - domain name (29 characters max.) n - 1 ~ 10 (slave ID)	UDP slave domain name
at+ set udp rs pn=p:n	p - port number (1 ~ 65535) n - 1 ~ 10 (slave ID)	UDP slave port number

### Serial Control Command Set

Command	Options	Description
at+set sp baudrate=br	br - 300, 1200, 2400, 4800, 9600, 19200, 38400, 57600, 115200, 230400	Baudrate
at+set sp data bits=db	db - 5, 6, 7, 8	Data bits
at+set sp parity bits=pb	pb - odd, even, none, space, mark	Parity bits
at+set sp stop bits=sb	sb - 1, 2	Stop bits
at+ set sp pr ps=ps	ps - 0 (no limit), 1~1024	Packing size
at+ set sp iqt=iqt	iqt - 0 (disable), 1 ~255 (unit: 20ms)	In-queue time
at+ set sp delimiter=dr	dr - del, del+1, del+2, del&stripped	Delimiter rule
at+ set sp del-code1=dc1	dc1 - disabled, 00 ~ FF (Hex code)	Delimiter code 1
at+ set sp del-code2=dc2	dc2 - disabled, 00 ~ FF (Hex code)	Delimiter code 2

### Maintenance Command Set

Command	Options	Description
at&reboot		Reboot the device
at&default		Restore factory default

## Appendix 1. RS-422 / RS-485

---

**EIA-485** [TIA-485] Balanced (differential) interface; defines the Physical layer, signaling protocol is not defined. EIA-485 specifies bidirectional, half-duplex data transmission. Up to 32 transmitters and 32 receivers may be interconnected in any combination, including one driver and multiple receivers (multi-drop), or one receiver and multiple drivers.

**EIA/TIA-422** define a Balanced (differential) interface; specifying a single, unidirectional driver with multiple receivers (up to 32). RS-422 will support Point-to-Point, Multi-Drop topology, but not Multi-Point [EIA485]. EIA-485 devices may be used in 422 circuits, but EIA-422 may not be used in 485 circuits (because of the lack of an Enable line). The published TIA/EIA 485 and RS-422 standards define only the electrical characteristics of the drivers and receivers as listed below. They did not standardize such things such as cables and connectors, pin-outs, bus arbitration, signaling protocols, or physical wiring topology. Many different implementations have come into use and they are often incompatible with each other.

Characteristics	RS-422	RS-485
Mode of operation	Differential	Differential
	Unidirectional	Full Duplex
	Multipoint	Multipoint
Allowed no. of Tx and Rx	1 Tx, 10 Rx	32 Tx, 32 Rx
Maximum cable length	4000ft length	4000ft length
Maximum data rate	10Mbps	10Mbps
Minimum Tx driver output range	+/- 2V +/- 1.5V	+/- 2V +/- 1.5V
Maximum Tx driver output range	+/- 5V	+/- 5V
Maximum Tx short-circuit current	150mA	250mA
Tx load impedance	100	54
Rx input sensitivity	+/- 200mV	+/- 200mV
Maximum Rx input resistance	4k	12k
Rx input voltage range	+/- 7V	-7V to +12V
Rx logic high	>200mV	>200mV
Rx logic low	<200mV	<200mV

RS-485 and RS-422 are in wide use as an interface for telecommunications, industrial, medical, security and networking applications. The following sections describe examples of some of popular physical topologies.

### A1.1 RS-422 Point-to-Point Circuit

This is the simplest configuration, just one driver and one receiver. If termination is used, it is only required at the receiver end. Most RS-422 cables used to connect telecom or data-com equipment are point to point links.

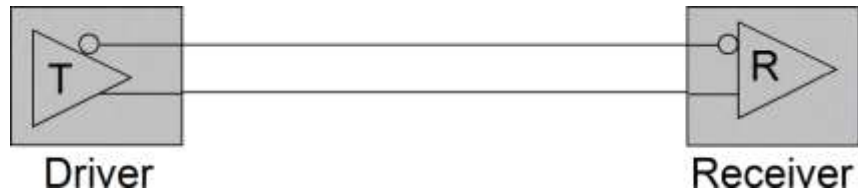

### A1.2 RS-422 Multi-drop Network

In this topology there is only one driver sending to one or more receivers. One termination resistor is recommended at the extreme end of the bus to eliminate reflections. Up to 10 receivers are permitted under RS-422. Multiple receive-only nodes may be used for point-to-multipoint communications.

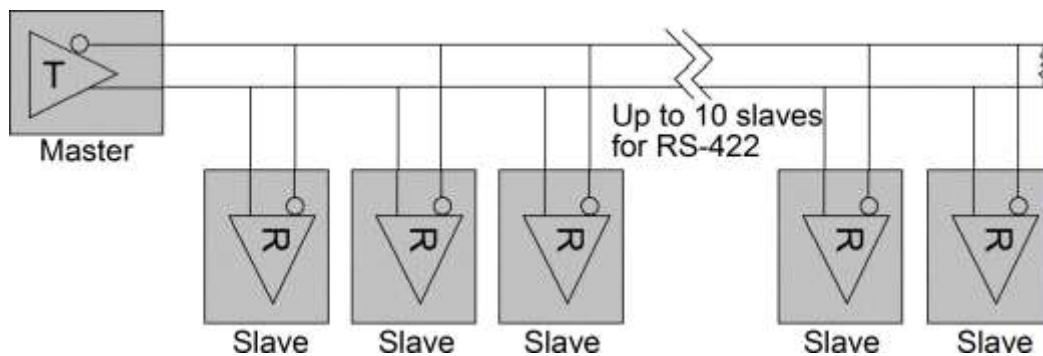

### A1.3 RS-485 Multi-drop Network

This topology is similar to RS-422 multi-drop. However, up to 32 receivers are permitted under RS-485. This may be used for point-to-multipoint communications.

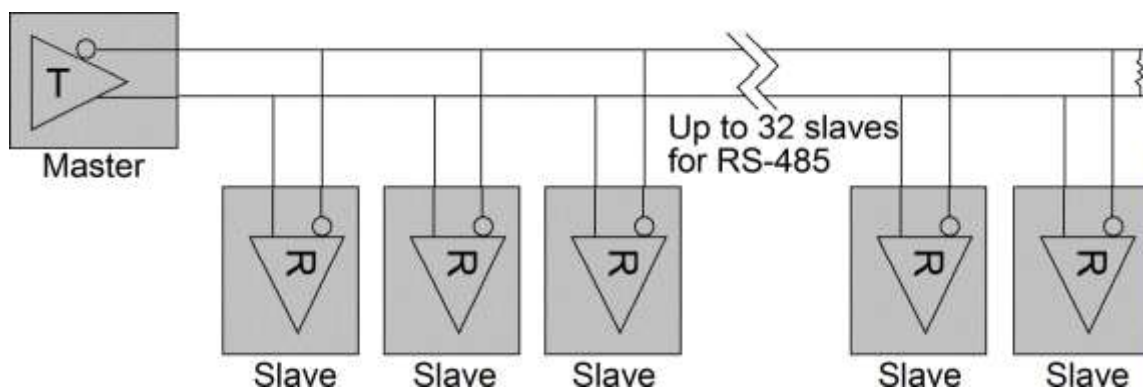

## A1.4 RS-485 Half-duplex 2-wire Network

This is the typical RS-485 topology. It takes advantage of RS-485 capability to support multiple drivers on a bus. RS-422 devices should not be used in this configuration. This topology enables bidirectional communication from many nodes over long distances at low to medium data rates, all on a single pair of wires (2-wire). It can implement a very functional, very flexible and very economical data network. Because signals travel in both directions, this bus should be terminated at both ends to prevent reflections. Only one node can drive the bus at a time, making this a half-duplex communication channel. Only one driver should be active at any one time. Therefore the transceivers used on a half-duplex bus should support a [Driver Enable](#) function.

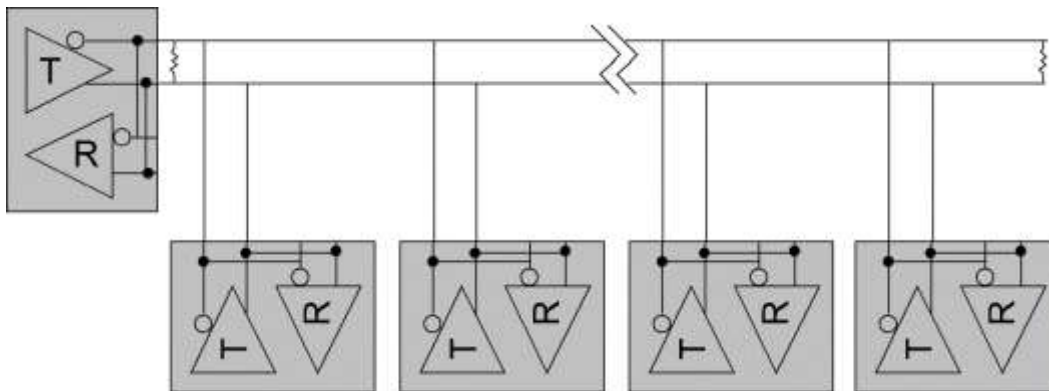

## A1.5 RS-485 Full-duplex 4-wire Network

The 4-wire network simplifies bus arbitration in multi-node RS-485. A single Master node is the only driver allowed on the top most wire pair. All other nodes listen to all data traffic that passes on the party-line type multi-drop bus. Nodes may transmit on the lower pair of wires when addressed by the master node or by using a software token-passing bus arbitration scheme.

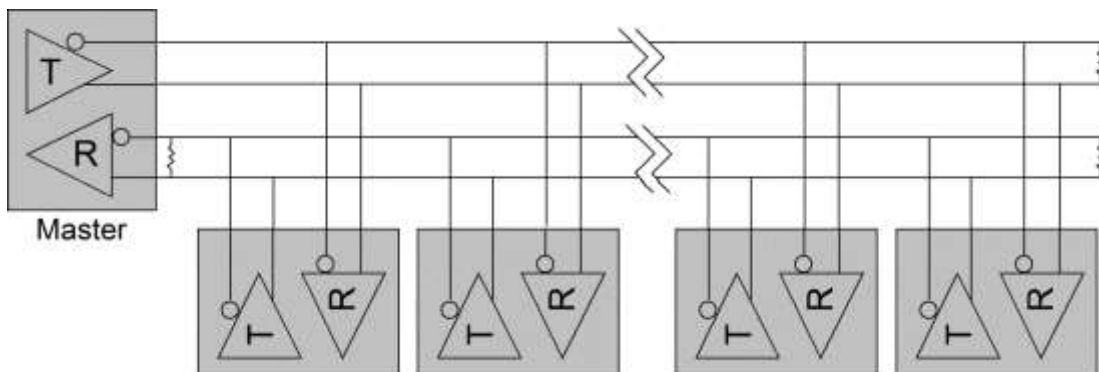

## Appendix 2. VCOM Program for Windows

---

Ethernet VCOM software program is contained in the product CD of the converter. It is free and used to map the serial port of a remote converter to a COM port number for Windows PC such that a remote converter's serial port can be accessed (read/write serial data) like a local physical COM port over a LAN topology. It allows the converter to be compatible with most of existing serial applications for Windows.

### A2.1 Functions of VCOM

The purpose of VCOM:

1. Search Device
2. Create/Remove/Configure Virtual Com ports

### A2.2 Installing the VCOM Program

The software is called “VCOM utility for windows2000/xp/2003/2008/Vista/Windows 7(x86/x64)”. However, it is also compatible to Windows 8 and Windows 10.

The steps for installation are:

1. Locate and run VCOMSETUP.EXE file in the product CD on your Windows system.
2. Follow the steps as follows until VCOM installation complete:

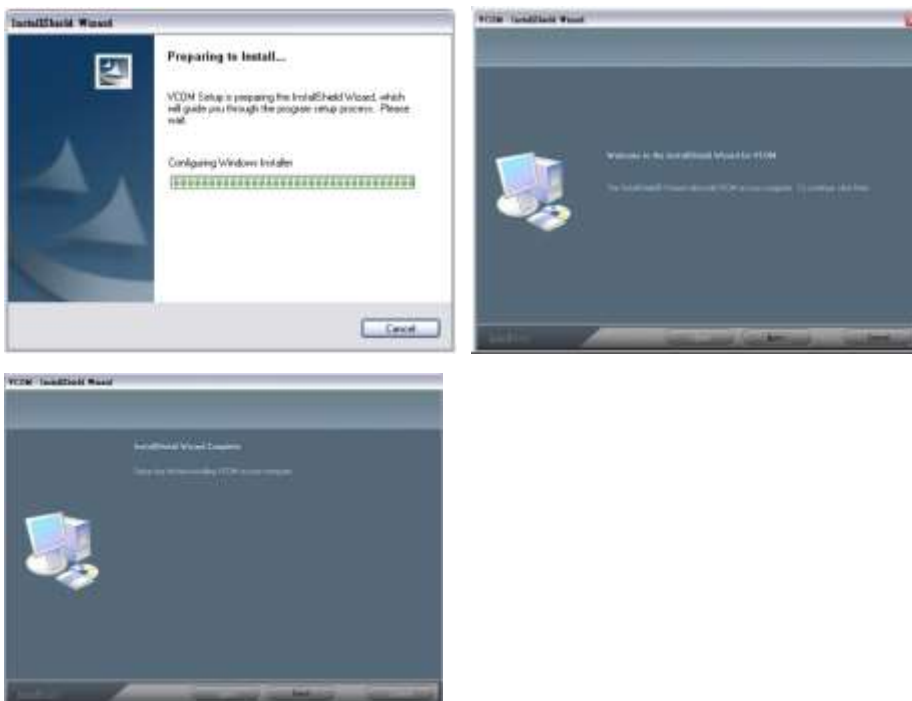

3. Follow the steps for WinPcap installation:



4. Installation complete.

## A2.3 VCOM Program Operation

VCOM provides “Device Info” and “COM Mapping” operations as follows:

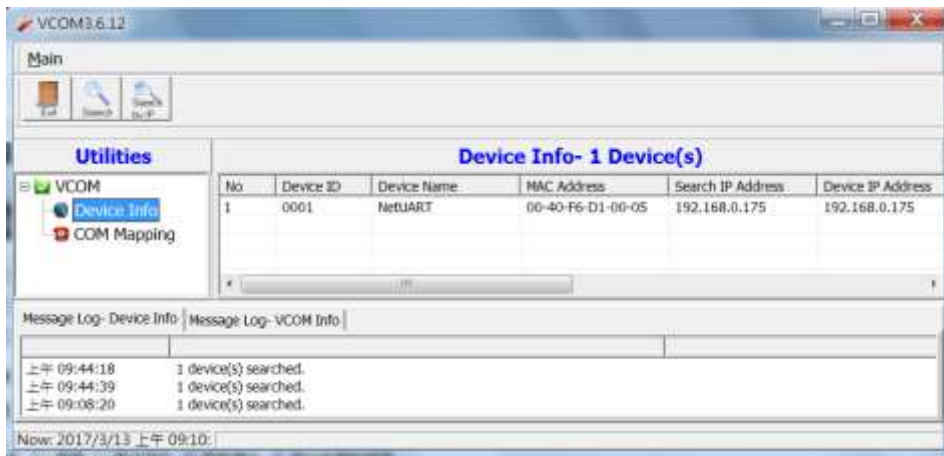

### Device Info

Two buttons are provided to:

1. Search: Click to search all VCOM compatible devices in network.
2. Search by IP: Click to search the devices in the specified IP ranges.



## COM mapping

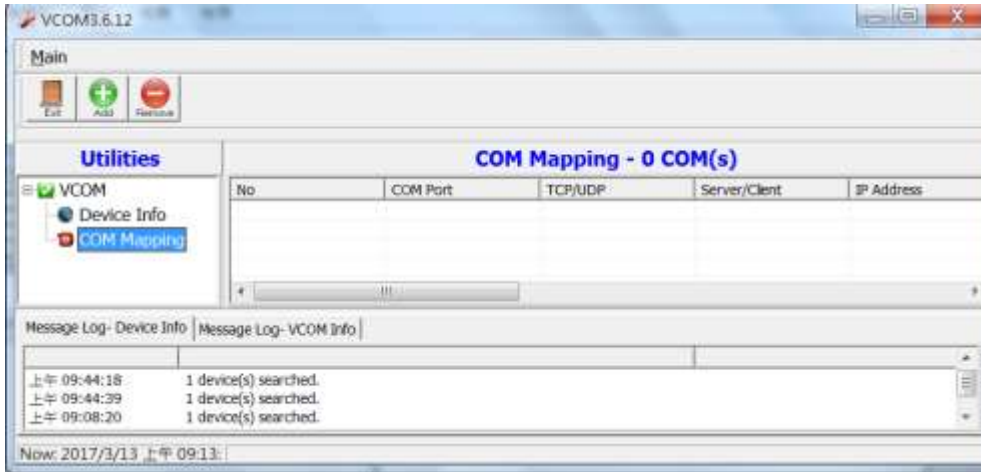

Click  to create a COM mapping.

Select the target device for your mapping from the search list.

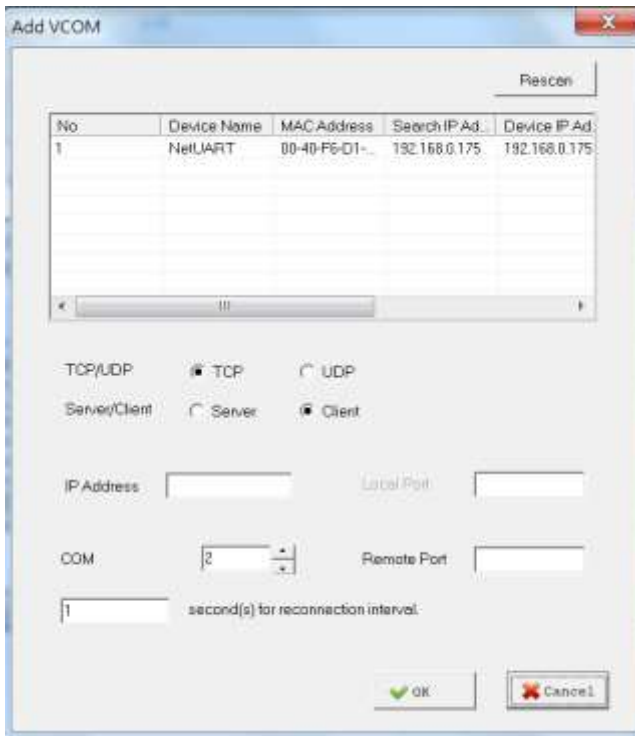

## Delete COM Mapping

Specify the existing COM port number to be deleted first in the list.

Click  to remove the specified COM port mapping from the list.



### Auto Start for Windows

Click “Auto-start Setting” command in Main menu, as illustrated below, to get VCOM enabled to auto start for Windows.

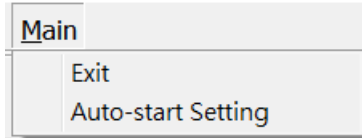

### A2.4 Alternative Solution beside VCOM Program

Refer to <https://www.eltima.com/products/serial-over-ethernet/> for professional solution with similar features provided by VCOM program.