



KPW-1012-D

Din-Rail AC-DC 12V Power Supply

User's Manual



DOC.131030

(C) 2011-2013 KTI Networks Inc. All rights reserved. No part of this documentation may be reproduced in any form or by any means or used to make any derivative work (such as translation or transformation) without permission from KTI Networks Inc.

KTI Networks Inc. reserves the right to revision and to make changes in content from time to time without obligation on the part of KTI Networks Inc. to provide notification of such revision or change.

For more information, contact:

United States KTI Networks Inc.
P.O. BOX 631008
Houston, Texas 77263-1008

Phone: 713-2663891
Fax: 713-2663893
E-mail: kti@ktinet.com
URL: <http://www.ktinet.com/>

International Fax: 886-2-26983873
E-mail: kti@ktinet.com.tw
URL: <http://www.ktinet.com.tw/>

The information contained in this document is subject to change without prior notice.

Copyright (C) All Rights Reserved.

FCC NOTICE

This device complies with Part 15 of the FCC Rules. Operation is subject to the following two conditions: (1) This device may not cause harmful interference, and (2) This device must accept any interference received, including the interference that may cause undesired operation.

CE NOTICE

Marking by the symbol indicates compliance of this equipment to the EMC directive of the European Community. Such marking is indicative that this equipment meets or exceeds the following technical standards:

EMC Class A

EN55022/2006+A1/2007

EN61000-3-2/2006

EN61000-3-3/2008 Class A

EN 55024/1998+A1/2001+A2/2003

EN 61000-4-2/2009

EN 61000-4-3/2006+A1/2008

EN 61000-4-4/2004

EN 61000-4-5/2006

EN 61000-4-6/2009

EN 61000-4-8/1993+A1/2001

EN 61000-4-11/2004

Specifications



AC Power Input

| | |
|---------------------|-------------------|
| Interfaces | IEC320 receptacle |
| Rated Input Voltage | 100 ~ 240VAC |
| No load Consumption | < 0.3W |

DC Power Output

| | |
|--------------|---|
| Interfaces | Type 1: Screw-type terminal block (Vout+, Vout-) Type 2: DC plug via the bundled DC plug cable |
| Output Power | +12VDC (+/- 1%), 0.85A max. |

Protection

Short Circuit, Over Load, Over Voltage

Mechanical

| | |
|------------------|--|
| Dimension (base) | 32 x 51 x 95 mm (W x D x H) |
| Housing | Enclosed metal |
| Mounting | Din-Rail mounting, Panel mounting, Wall mounting, Desktop mounting |

Environmental

| | |
|-----------------------|--------------------------|
| Operating Temperature | - 25°C ~ + 70°C |
| Storage Temperature | - 40°C ~ + 85°C |
| Relative Humidity | 10% ~ 90% non-condensing |

Internal Power Module Approvals

| | |
|----------------------|---|
| Safety Certification | UL 60601-1, IEC60601-1, EN 60601-1 UL 60950-1, IEC 60950-1, EN 60950-1 |
|----------------------|---|

Electrical Approvals

| | |
|--------------|---|
| FCC | Part 15 rule Class A |
| CE EMC | EN55022/2006+A1/2007 EN61000-3-2/2006 EN61000-3-3/2008 Class A EN 55024/1998+A1/2001+A2/2003 EN 61000-4-2/2009 EN 61000-4-3/2006+A1/2008 EN 61000-4-4/2004 EN 61000-4-5/2006 EN 61000-4-6/2009 EN 61000-4-8/1993+A1/2001 EN 61000-4-11/2004 |
| VCCI | VCCI V-3/2010.04, Class A VCCI V-4/2010.04, Class A |
| Safety | CE LVD TUV EN 60950-1 Certified |
| Special Test | NEMA TS2-2003 Environment: Endurance Vibration, Mechanical shock test, Temperature/Humidity test (Condition combination : -34°C ~ +74°C, 0 ~90%RH) |

MTBF

136K Hours

Installation

Unpacking

The product package contains:

- The power supply unit
- One DC plug cable
- DIN-Rail mounting bracket
- One product CD-ROM
- One AC power cord

Safety Cautions

To reduce the risk of bodily injury, electrical shock, fire and damage to the product, observe the following precautions.

- Do not service any product except as explained in your system documentation.
- Opening or removing covers may expose you to electrical shock.
- Only a trained service technician should service components inside these compartments.
- If any of the following conditions occur, unplug the product from the electrical outlet and replace the part or contact your trained service provider:
 - The power cable, extension cable, or plug is damaged.
 - An object has fallen into the product.
 - The product has been exposed to water.
 - The product has been dropped or damaged.
 - The product does not operate correctly when you follow the operating instructions.
- Do not push any objects into the openings of your system. Doing so can cause fire or electric shock by shorting out interior components.
- Operate the product only from the type of external power source indicated on the electrical ratings label. If you are not sure of the type of power source required, consult your service provider or local power company.
- For pluggable equipment, the socket-outlet shall be installed near the equipment and shall be easily accessible.
- An approved power supply cord not lighter than IEC 60227, H03VV-F, 3G, 0.75mm² or alternatively IEC 60245, H05RR-F, 3G, 0.75mm².

Din-Rail Mounting

Install the Din-Rail bracket on the rear panel as shown below:



Mount the device unit on a Din-Rail as shown below:



Final Dimension after Installation

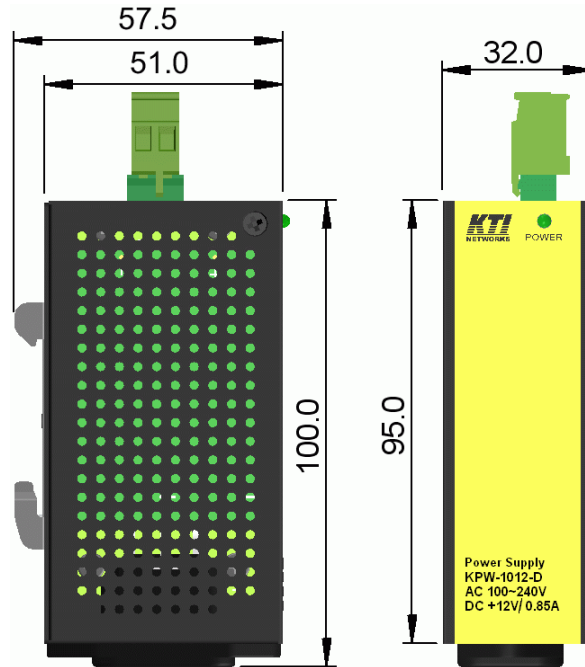

Panel Mounting

An optional panel mounting bracket supports mounting the power supply on a plane surface securely.

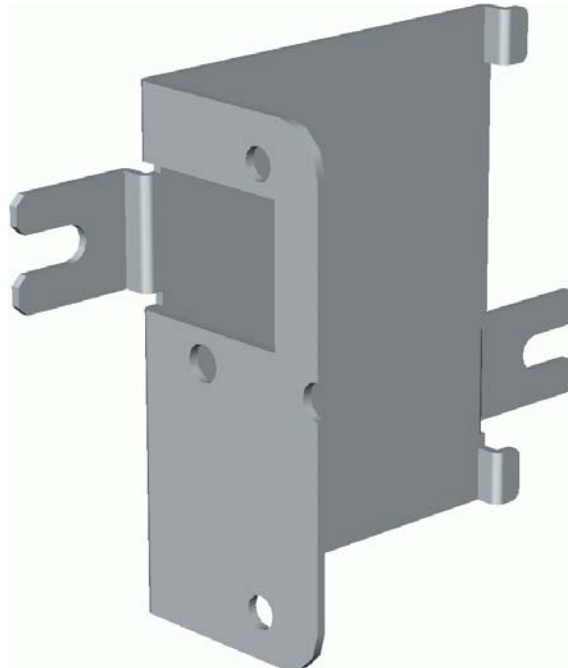

Install the bracket onto the device unit as shown below and use two screw holes to fix the unit on a plane surface:



Final Dimension after Installation

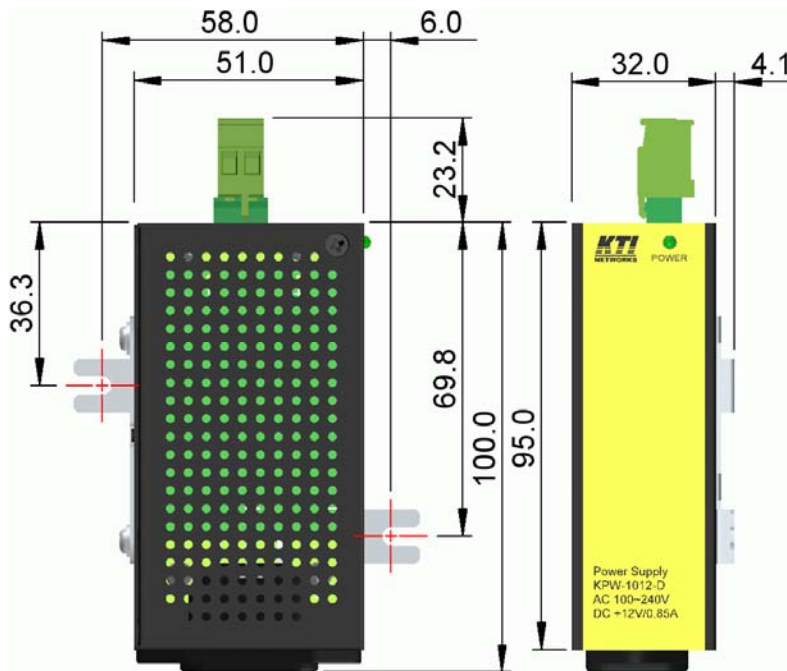

AC Power Input

The power supply provides IEC320 for receiving AC power input.



Using IEC320 Interface

One AC power cord which meets the specification of your country of origin is supplied in package. Plug the power cord into the IEC320 receptacle properly.



DC Power Output

The power supply provides industrial terminal block connectors for installations and one typical DC plug support for commercial installation.

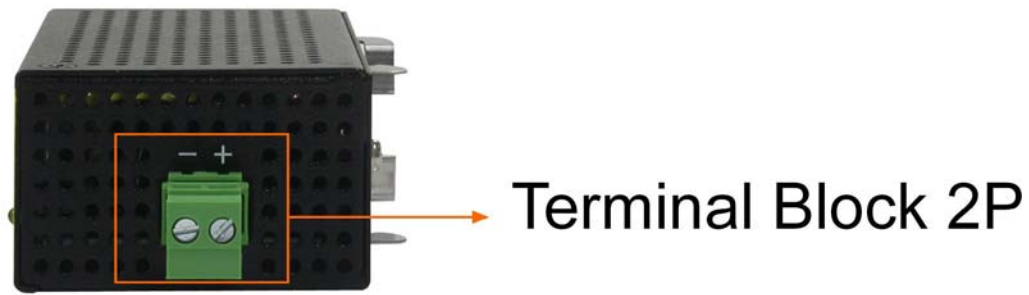

Using Terminal Blocks

DC OUT (2P)

V_{out+} terminal

V_{out-} terminal

(V_{out+} : +12VDC, 0.85A total max.)

Use the supplied 2P plug for DC power wires. Insert and screw the wires securely as shown below:



Power wire specification: 24~12AWG (IEC 0.5~2.5mm²)

Plug the wired DC plug into DC OUT socket as shown below.



Using DC plug cable

To support the devices which have only DC IN Jack interface, one DC plug cable shown below is supplied.

DC Plug Cable



Insert the cable into DC OUT terminal block of the power unit as illustrated below and uncover any unused contacts.



An Example of supplying power to a device with DC Jack.

