



**Industrial
RS-232 to RS-485/422 Converter**

KSC-240

Installation Guide



DOC.150116-KSC-240

(C) 2015 KTI Networks Inc. All rights reserved. No part of this documentation may be reproduced in any form or by any means or used to make any directive work (such as translation or transformation) without permission from KTI Networks Inc.

KTI Networks Inc. reserves the right to revise this documentation and to make changes in content from time to time without obligation on the part of KTI Networks Inc. to provide notification of such revision or change.

For more information, contact:

United States

KTI Networks Inc.
P.O. BOX 631008
Houston, Texas 77263-1008

Phone: 713-2663891
Fax: 713-2663893
E-mail: kti@ktinet.com
URL: <http://www.ktinet.com/>

International

Fax: 886-2-26983873
E-mail: kti@ktinet.com.tw
URL: <http://www.ktinet.com.tw/>

The information contained in this document is subject to change without prior notice. Copyright (C) All Rights Reserved.

TRADEMARKS

Ethernet is a registered trademark of Xerox Corp.

FCC NOTICE

This device complies with Class B Part 15 the FCC Rules. Operation is subject to the following two conditions: (1) This device may not cause harmful interference, and (2) this device must accept any interference received including the interference that may cause.

CE NOTICE

Marking by the symbol  indicates compliance of this equipment to the EMC directive of the European Community. Such marking is indicative that this equipment meets or exceeds the following technical standards:

EMC Class B

EN 50081-1 : EN55022 Class B

EN61000-3-2

EN61000-3-3

EN 55024:1998/A1:2001

IEC 61000-4-2

IEC 61000-4-3

IEC 61000-4-4

IEC 61000-4-5

IEC 61000-4-6

IEC 61000-4-8

IEC 61000-4-11

Table of Contents

1. Introduction	5
1.1 Features	6
1.2 Specifications	7
2. Installation	12
2.1 Unpacking	12
2.2 Safety Cautions	13
2.3 DIN-Rail Mounting	14
2.4 Panel Mounting	16
2.5 Applying Power	18
2.6 Power Failure Relay Output	21
2.7 DIP SW Configuration	22
2.7.1 RS-485/422 Driver and Receiver Control	28
2.8 Making Serial RS-232 Connection	29
2.8.1 Cable for Connection to PC COM Port	31
3 Making RS-485/422 Connection	32
3.1 RS-422 Point-to-Point Circuit	33
3.2 RS-422 Multi-drop Network	34
3.3 RS-485 Multi-drop Network	36
3.4 RS-485 Half-duplex 2-wire Network	38
3.5 RS-485 Full-duplex 4-wire Network	39
3.6 Summary of the Converter Applications	41
4 LED Indicators	42
4.1 LED Indicators	42
5 Factory Default Configuration	43

1. Introduction

The industrial converter is designed to convert RS-232 signals to optically isolated, balanced, full or half-duplex RS-422 or RS-485 signals at baud rate up to 115.2Kbps. It features RTS control design, which allows software to control RS-485 transmission. With smart ADC™ (Auto Data Control) design, the converter can use send data signal to control RS-485 transmission automatically so no software control is required in RS-485 mode. The Din-rail mountable design makes it ideal for industrial cabinets and enclosures. Further, more designs such as signal protection, wide operating temperature range, wide power voltage range are provided to suit for more industrial applications.



For industrial environment, the converters are designed with the following enhanced features exceeding that of commercial media converters:

- High and wide operating Temperature
- Wide operating voltage range for DC power input
- Power input interface: Industrial screw terminal block and DC power jack for external commercial power adapter as option
- DIN rail mounting support for industrial enclosure
- Screw panel mounting support for industrial enclosure
- Industrial-rated Emission and Immunity performance

1.1 Features

- Supports RS-232 baud rate up to 115.2Kbps
- Operation with no required configuration
- Provides surge protection (transient voltage) on all interface lines
- Provides high ESD protection on all line signals
- Optical isolated between RS-232 and RS-485/422 interfaces
- Supports RS-422, 2-wire RS-485, and 4-wire RS-485 network
- Supports full-duplex or half-duplex for RS-485/422 interface
- Provides remote RTS control for RS-485 transmission
- Provides ADC™ (Auto Data Control) for RS-485 transmission
- Designed for industrial environments with:
 - Surge, ESD, and isolation protection
 - DIN-rail and panel mounting support
 - Wide power voltage range support
 - Terminal block and Jack-type power connectors
 - Wide operating temperature range support
 - Alarm relay output for device power failure
 - Industrial-rated emission and immunity performance

1.2 Specifications

This figure shows the important components of the device:

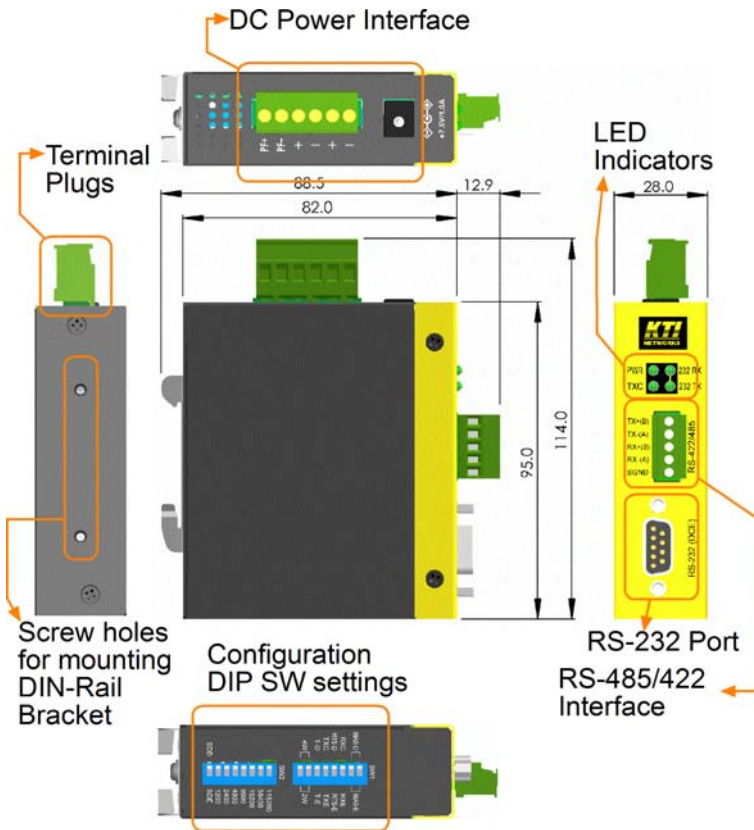

Serial Interface (RS-232 Port)

Connector	DB9 female
Pin Assignments	DCE type
Baud Rate Support	Up to 115K baud
Connector Shield	Connect to chassis ground
Connection Distance	15 meters
High ESD Tolerance	+/-15KV on Tx, Rx lines
Overvoltage Protection	Cutoff if over +/-28V
Isolation	Optical isolation with RS-485/422 interface

RS-485/422 Interface

Connector	Screw-type terminal block
Signal Type	Balanced differential lines
Data Speed	115Kbps
Standard	EIA-485, EIA-422
High ESD Tolerance	+/-15KV on driver and receiver lines
Overvoltage Protection	Cutoff if over +/-28V

LED Indicators

<u>LED</u>	<u>DISPLAY</u>	<u>STATE</u>	<u>INTERPRETATION</u>
PWR	Power status	ON	Power on
		OFF	Power off
232 TX	RS-232 TX	BLINK	RS-232 TX Activity
232 RX	RS-232 RX	BLINK	RS-232 RX Activity
TXC	RS-485/422 TX control	ON	RS-485 driver is enabled
		OFF	RS-485 driver is disabled

Configuration DIP SW Settings

SW	Name	State	Function
SW1-2&1	4W	Off	4-wire (RS-485/422 driver receiver separated)
	2W	On	2-wire (RS-485/422 driver receiver connected)
SW1-3	T-D	Off	Disable RS-485/422 receiver terminator
	T-E	On	Enable RS-485/422 receiver terminator
SW1-4	TXC	Off	RS-485/422 driver enable control by RTS or ADC
	TXE	On	RS-485/422 driver is forced to enable
SW1-5	RTS-D	Off	Disable RTS control for RS-485/422 TX RX
	RTS-E	On	Enable RTS control for RS-485/422 TX RX
SW1-6	RXC	Off	RS-485/422 receiver enable control by RTS or ADC
	RXE	On	RS-485/422 receiver is forced to enable.
SW1-8&7	BIAS-D	Off	RS-485/422 line bias is disabled
	BIAS-E	On	RS-485/422 line bias is enabled
SW2-1	SDD	Off	Disable ADC control for RS-485/422 TX RX
	SDE	On	Enable ADC control for RS-485/422 TX RX
SW2-2	1200	On	ADC Timing parameter for RS-232 baud 1200
SW2-3	2400	On	ADC Timing parameter for RS-232 baud 2400
SW2-4	4800	On	ADC Timing parameter for RS-232 baud 4800
SW2-5	9600	On	ADC Timing parameter for RS-232 baud 9600
SW2-6	19200	On	ADC Timing parameter for RS-232 baud 19200
SW2-7	38400	On	ADC Timing parameter for RS-232 baud 38400
SW2-8	115200	On	ADC Timing parameter for RS-232 baud 115200

DC Power Interface

Interface	Screw-type terminal block 1. Two pairs for power wire cascading 2. One pair for power failure relay output
Operating Input Voltages	DC Jack (-D6.3mm/+D2.0mm) +7V ~ +30V(+5%)
Power consumption	0.6W @+7.5VDC, 12VDC, 30VDC input

Basic Information

Conversion	RS-232 RX data to RS-485/422 TX data RS-485/422 RX data to RS-232 TX data
Optical Isolation	Isolated between RS-232 and RS-485/422 3000VDC rms

Mechanical

Dimension (base)	W 28mm x D 82mm x H 95mm
Housing	Enclosed metal with no fan
Mounting Support	DIN-rail mounting, Panel mounting
Weight	240g

Environmental

Operating Temperature	-20°C ~ 70°C
Storage Temperature	-20°C ~ 85°C
Relative Humidity	10% ~ 90%

Certificate

FCC
CE/EMC

Part 15 Class B
EMI EN50081-1 Class B
EMS EN55024
EN 60950

CE/LVD Safety

EN 50081-1
EN55022
EN61000-3-2
EN61000-3-3

EN 55024

IEC 61000-4-2	ESD Test
IEC 61000-4-3	RS Test
IEC 61000-4-4	EFT/BURST Test
IEC 61000-4-5	Surge Test
IEC 61000-4-6	CS Test
IEC 61000-4-8	Magnetic Field
IEC 61000-4-11	Volatge Int. Dips

2. Installation

2.1 Unpacking

Check that the following components have been included:

- Information CD
- The device unit
- DIN-rail mounting bracket

If any item is found missing or damaged, please contact your local reseller for replacement.

The following are available optional accessories:

- Panel Mounting Bracket
The bracket is used for mounting the device on a panel surface.
- Commercial-rated AC power adapters:
 - Rated AC120V/60Hz DC7.5V 1A
 - Rated AC230V/50Hz DC7.5V 1A
 - Rated AC100V/50-60Hz DC7.5V 1A
 - Rated AC240V/50Hz DC7.5V 1A

The adapters are used for supplying DC power to the converter via DC power jack interface.

2.2 Safety Cautions

To reduce the risk of bodily injury, electrical shock, fire, and damage to the equipment, observe the following precautions.

- Do not service any product except as explained in your system documentation.
- Opening or removing covers may expose you to electrical shock. Only a trained service technician should service components inside these compartments.
- If any of the following conditions occur, unplug the product from the electrical outlet and replace the part or contact your trained service provider:
 - The power cable, extension cable, or plug is damaged.
 - An object has fallen into the product.
 - The product has been exposed to water.
 - The product has been dropped or damaged.
 - The product does not operate correctly when you follow the operating instructions.
- Do not push any objects into the openings of your system. Doing so can cause fire or electric shock by shorting out interior components.
- Operate the product only from the type of external power source indicated on the electrical ratings label. If you are not sure of the type of power source required, consult your service provider or local power company.

2.3 DIN-Rail Mounting

In the product package, a DIN-rail bracket is installed on the device for mounting the converter in a industrial DIN-rail enclosure.

The steps to mount the device onto a DIN rail are:

1. Install the mounting bracket onto the device unit as shown below:

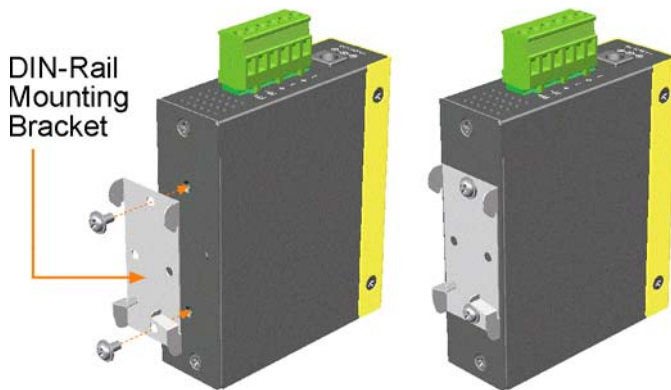

2. Attach bracket to the lower edge of the DIN rail and push the unit upward a little bit until the bracket can clamp on the upper edge of the DIN rail.
3. Clamp the unit to the DIN rail and make sure it is mounted securely.
4. Make sure that there are proper heat dissipation from and adequate ventilation around the device.

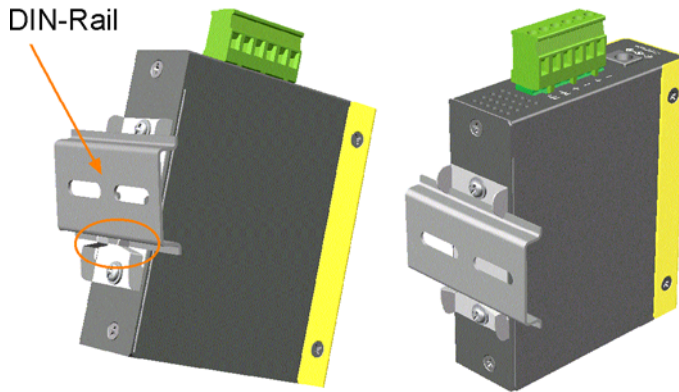

The final mechanical dimensions after installing DIN rail mounting bracket are:

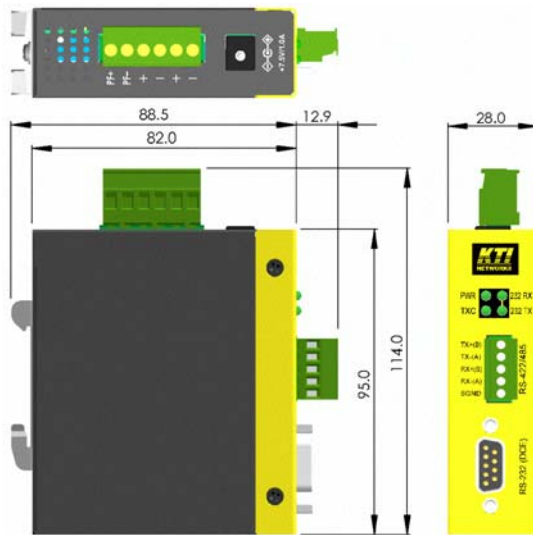

2.4 Panel Mounting

The device is provided with an optional panel mounting bracket. The bracket support mounting the device on a plane surface securely. The mounting steps are:

1. Install the mounting bracket on the device unit.
2. Screw the bracket on the device unit.

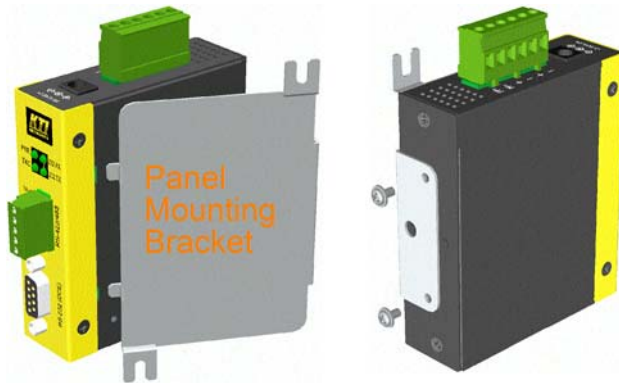

3. Screw the device unit on a panel.
4. Make sure that there are proper heat dissipation from and adequate ventilation around the device. Do not place heavy objects on the device.

The screw locations and final dimension are shown below:

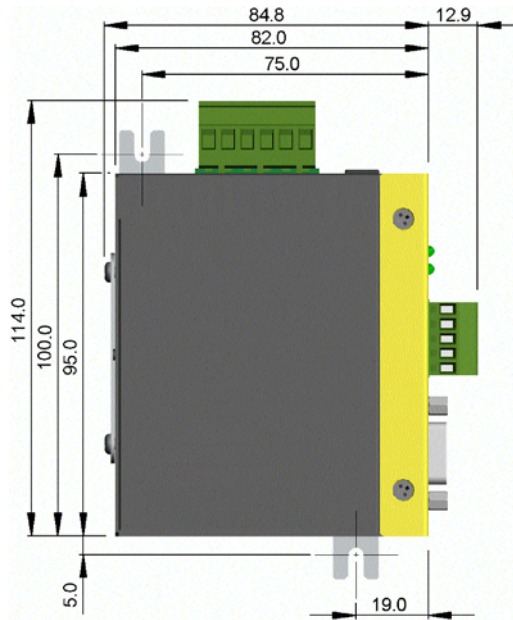

2.5 Applying Power

The power specifications of the device are:

Operating Voltage +7~+30VDC

Power Consumption Max. 0.6W @+30VDC, +12VDC, +7.5VDC

The device provides two types of power interfaces, terminal block and DC power jack for receiving DC power input from external power supply.

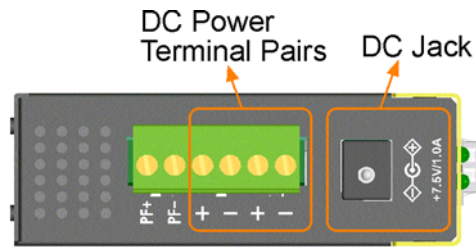

Using Terminal Blocks

Either DC1 interface or DC2 interface can be used to receive DC power from an external power system. Or, DC2 also can be used to deliver the power received on DC1 to next device in cascading way.

DC1 +	Vdc Positive (+) terminal
DC1 -	Vdc Negative (-) terminal
DC2 +	Vdc Positive (+) terminal
DC2 -	Vdc Negative (-) terminal

Three 2P terminal plugs are provided together with the device. Two of the three plugs are used for DC1 and DC2 interfaces respectively. The plug is shown below:



Power wires: 24 ~ 12AWG (IEC 0.5~2.5mm²)

Install the power source wires with the plug properly. Screw the wire with plug securely. Then, plug in DC1 contacts.

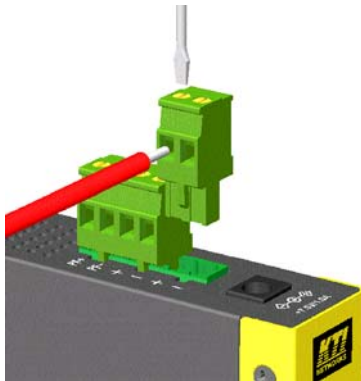

If cascading the power to next device is needed, install the power wires and plug for another switch. Then, use DC2 contacts.

Note: Only up to four device units can be cascaded to receive power from one main power input source.

Using DC Power Jack

DC Jack Connector: Jack D 6.3mm —  +D 2.0mm

AC Power Adapters: Optional commercial rated adapters are available for purchasing.

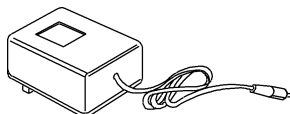

Rated AC120V/60Hz DC7.5V 1A
Rated AC230V/50Hz DC7.5V 1A
Rated AC100V/50-60Hz DC7.5V 1A
Rated AC240V/50Hz DC7.5V 1A

Connect power adapter DC plug to the DC power jack of the converter before connecting to the AC outlet. Connect the power adapter to the AC outlet.



Note: Before you begin the installation, check the AC voltage of your area. The AC power adapter which is used to supply the DC power for the unit should have the AC voltage matching the commercial power voltage in your area.

2.6 Power Failure Relay Output

The device provides a relay output to report power failure event to a remote alarm monitoring system. The relay output is provided with two contacts labeled **PF+** and **PF-** in the terminal block interface.

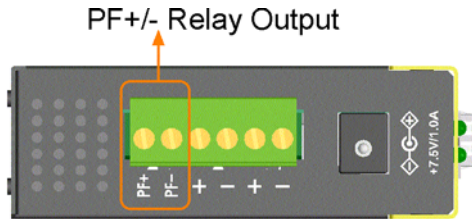

Use the provided 2P terminal plug for signal wiring and plug into the PF+/- contacts. The function is designed as :

Power is normal PF+ / PF- disconnected (open)

Power failure PF+ / PF- shorted

Note: Be sure the voltage applied on PF+/- contacts is within the specification of 30VDC/1A max. or 120VAC/0.5A max.

2.7 DIP SW Configuration

SW1-2 & 1

4W 4-wire (RS-485/422 driver receiver separated)

2W 2-wire (RS-485/422 driver receiver connected)

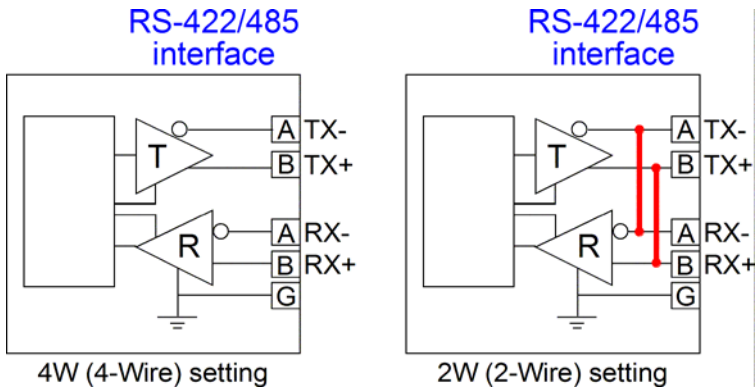

[2W] setting activates the internal connection between driver and receiver in RS-485/422 interface. It simplifies the installation of the converter in a 2-wire bus. RS-422 usually uses 2-wire topology only. RS-485 supports both 2-wire and 4-wire topology.

SW1-3

T-D Disable RS-485/422 receiver terminator

T-E Enable RS-485/422 receiver terminator

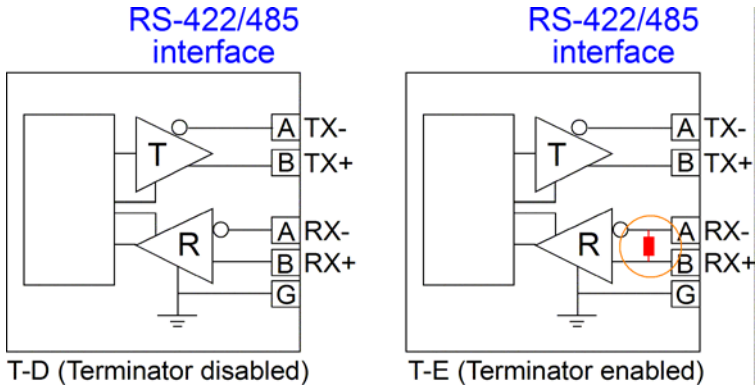

[T-E] setting enables the internal 120 ohms terminator on the receiver interface. A proper termination is important in a bus topology or multi-drop network. The terminator is a resistor added in parallel with the receiver's "A" and "B" lines in order to match the data line characteristic impedance and reduce signal reflection. This setting is useful when the converter is installed at the end of a RS-485 or RS-422 bus.

If the internal 120 Ohm terminator is not appropriate for your application, use [T-D] to disable it and use external one.

SW1-4

TXC RS-485/422 driver enable control by RTS or ADC

TXE RS-485/422 driver is forced to enable

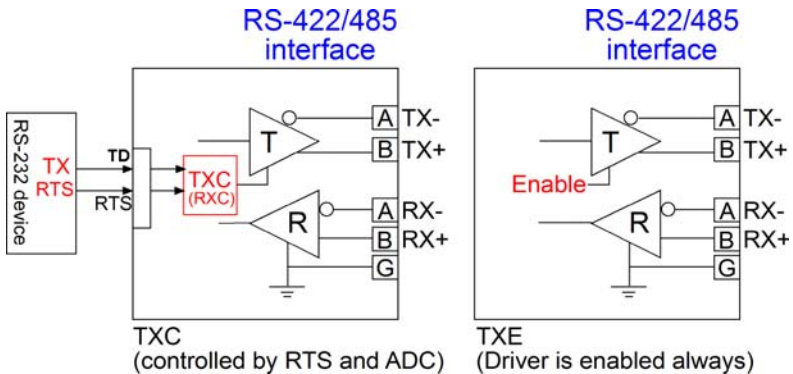

[TXC] setting enables RS-485/422 driver to be controlled by RTS method or ADC method. RTS method is described later. Refer to SW2 settings for more description about ADC method.

[TXE] setting forces RS-485/422 driver to be enabled always. This setting is applied when Master function is required in an RS-485/RS-422 multi-drop bus.

SW1-5

- RTS-D Disable RTS control for RS-485/422 driver
- RTS-E Enable RTS control for RS-485/422 driver

RTS control method allows the connected RS-232 device (such as a PC) to control RTS signal (input at the converter end) by software to enable or disable RS-485/422 driver. [RTS-D] setting is used to disable RTS control method.

SW1-6

- RXC RS-485/422 receiver enable control by RTS or ADC
- RXE RS-485/422 receiver is forced to enable.

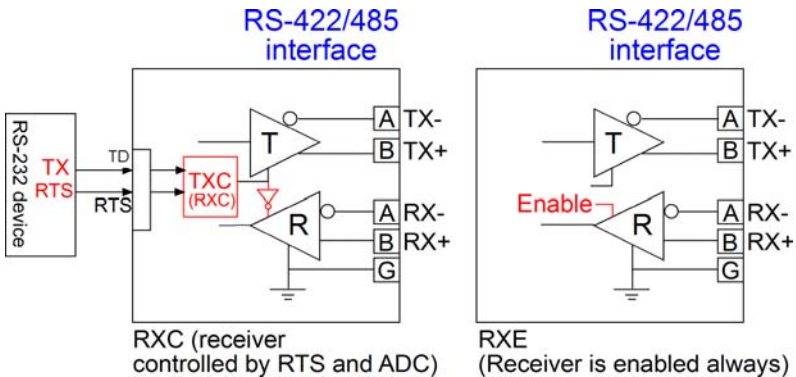

[RXC] setting enable to use the same [TXC] logic but reverse it as RXC for the RS-485/422 receiver control. It means when the driver is enabled the receiver is disabled. The receiver is enabled when the driver is disabled. This setting is applied when a half-duplex communication is adopted.

SW1-8&7

BIAS-D RS-485/422 receiver line bias is disabled

BIAS-E RS-485/422 receiver line bias is enabled

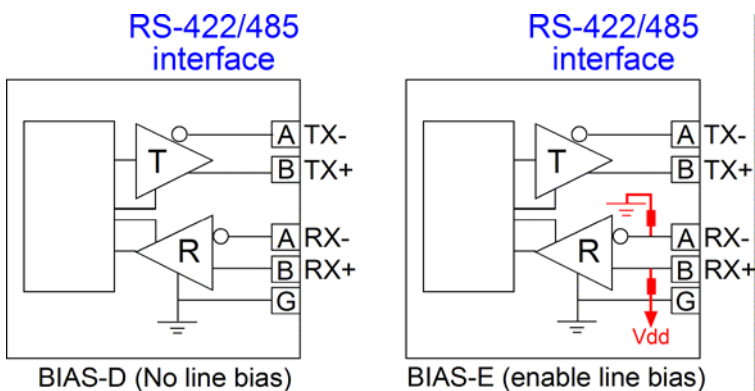

The line bias is used to maintain the proper idle-state voltage to the idle condition (when no driver is enabled on the bus). These bias resistors are pull-up resistors on the data B line and pull-down resistors (to ground) on data A line. In 4-wire configuration, the bias resistors are placed on the receiver lines. [BIAS-D] disables the internal BIAS resistors on receiver lines.

[BIAS-E] setting enables internal bias resistors. The bias configuration can support up to 30 receiver nodes with no terminators. If the bias configuration is not proper for your physical topology, set to [BIAS-D] and use external bias design according to your application.

SW2-1

SDD Disable ADC control for RS-485/422 driver

SDE Enable ADC control for RS-485/422 driver

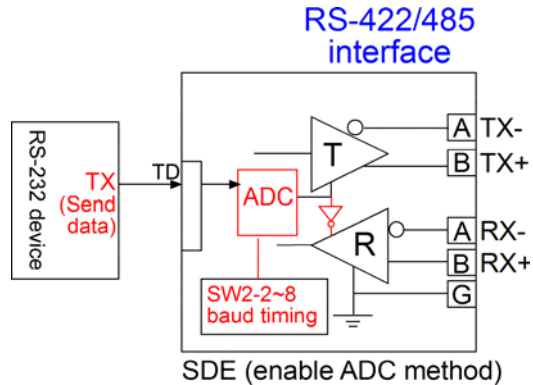

ADC method involves special circuitry that senses when data is received on the RS-232 interface and is being transmitted and automatically enables the RS-485/422 driver as well as disabling the driver within one character length of the end of transmission. This is a useful method for driver control since it needs no software involved.

In order to obtain an optimal performance, set SW2-2 ~ SW2-8 the associated timing parameter for each RS-232 baud rate.

SW2-2	1200	ADC Timing parameter for RS-232 baud 1200
SW2-3	2400	ADC Timing parameter for RS-232 baud 2400
SW2-4	4800	ADC Timing parameter for RS-232 baud 4800
SW2-5	9600	ADC Timing parameter for RS-232 baud 9600
SW2-6	19200	ADC Timing parameter for RS-232 baud 19200
SW2-7	38400	ADC Timing parameter for RS-232 baud 38400
SW2-8	115200	ADC Timing parameter for RS-232 baud 115200

2.7.1 RS-485/422 Driver and Receiver Control

The following table lists the possible DIP SW settings related to RS-485 and RS-422 driver and receiver control:

<u>SW1-4</u>	<u>SW1-6</u>	<u>SW1-5</u>	<u>SW2-1</u>	<u>Behavior</u>
TXE	RXC	RTS-D	SDD	Driver is enabled. Receiver is disabled.
TXE	RXE	-	-	Driver is enabled. Receiver is enabled.
TXC	RXE	RTS-D	SDD	Driver is disabled. Receiver is enabled.
TXC	RXE	RTS-E	SDD	Driver controlled by RTS Receiver is enabled.
TXC	RXC	RTS-E	SDD	Driver controlled by RTS Receiver is enabled when driver is disabled.
TXC	RXE	RTS-D	SDE	Driver controlled by ADC Receiver is enabled.
TXC	RXC	RTS-D	SDE	Driver controlled by ADC Receiver is enabled when driver is disabled.

2.8 Making Serial RS-232 Connection

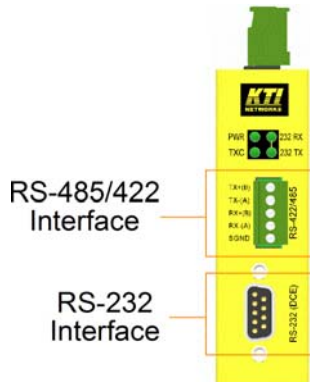

Typical RS-232 Interface DCE Pin Assignment Table

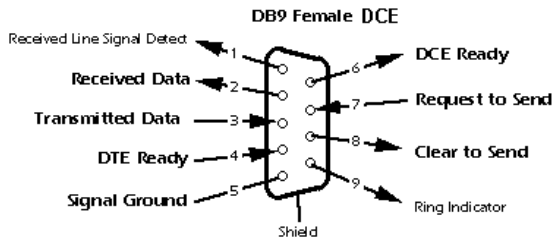

<u>Pin#</u>	<u>Signal Name</u>	<u>Input/Output</u>
1	Received Line Signal Detect	Output
2	RD, DTE Received Data	Output
3	TD, DTE Trasmitted Data	Input
4	DTR, DTE Ready	Input
5	Signal Ground	Output
6	DSR, DCE Ready	Output
7	RTS, Request To Send	Input
8	CTS, Clear To Send	Output
9	Ring Indicator	Output

The RS-232 to RS-485/422 converter as an interface between an RS-232 device and RS-485 or RS-422 bus. The connection is illustrated as follows:

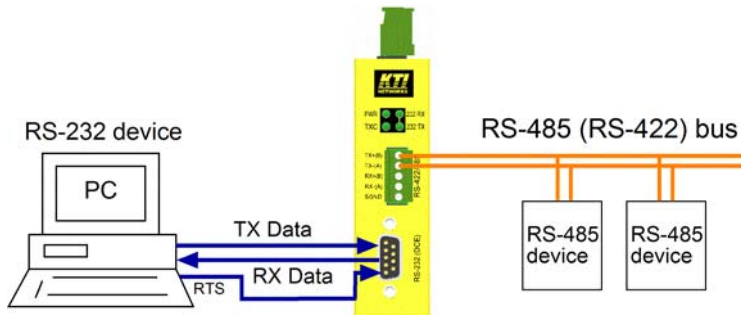

The following signals received on the RS-232 interface are converted to RS-485 bus signals:

<u>Pin#</u>	<u>Signal Name</u>	<u>Input/Output</u>
2	RD, DTE RX Data	Output
3	TD, DTE TX Data	Input
7	RTS, Request To Send	Input

2.8.1 Cable for Connection to PC COM Port

Connecting to 9-pin DTE device (Computer or PC COM)



Connecting to 25-pin DTE device (Computer or PC COM)

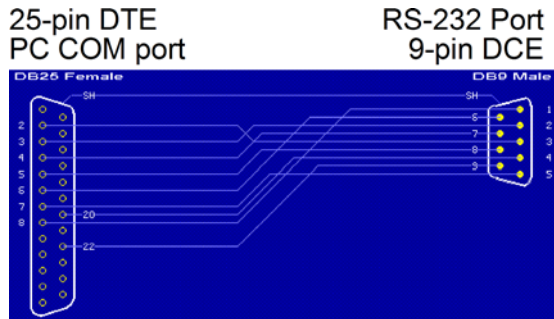

3 Making RS-485/422 Connection

EIA-485 [TIA-485] Balanced (differential) interface; defines the Physical layer, signaling protocol is not defined. EIA-485 specifies bidirectional, half-duplex data transmission. Up to 32 transmitters and 32 receivers may be interconnected in any combination, including one driver and multiple receivers (multi-drop), or one receiver and multiple drivers.

EIA/TIA-422 define a Balanced (differential) interface; specifying a single, unidirectional driver with multiple receivers (up to 32). RS-422 will support Point-to-Point, Multi-Drop topology, but not Multi-Point [EIA485]. EIA-485 devices may be used in 422 circuits, but EIA-422 may not be used in 485 circuits (because of the lack of an Enable line).

The published TIA/EIA 485 and RS-422 standards define only the electrical characteristics of the drivers and receivers as listed below. They did not standardize such things such as cables and connectors, pinouts, bus arbitration, signaling protocols, or physical wiring topology. Many different implementations have come into use and they are often incompatible with each other.

<u>Characteristics</u>	<u>RS-422</u>	<u>RS-485</u>
Mode of operation	Differential Unidirectional Multipoint	Differential Full Duplex Multipoint
Allowed no. of Tx and Rx	1 Tx, 10 Rx	32 Tx, 32 Rx
Maximum cable length	4000ft length	4000ft length
Maximum data rate	10Mbps	10Mbps
Minimum Tx driver output range	+/- 2V	+/- 1.5V
Maximum Tx driver output range	+/- 5V	+/- 5V
Maximum Tx short-circuit current	150mA	250mA
Tx load impedance	100	54
Rx input sensitivity	+/- 200mV	+/- 200mV
Maximum Rx input resistance	4k	12k
Rx input voltage range	+/- 7V	-7V to +12V
Rx logic high	>200mV	>200mV
Rx logic low	<200mV	<200mV

RS-485 and RS-422 are in wide use as an interface for telecommunications, industrial, medical, security and networking applications. The following sections describe examples of some of popular physical topologies.

3.1 RS-422 Point-to-Point Circuit

This is the simplest configuration, just one driver and one receiver. If termination is used, it is only required at the receiver. Most RS-422 cables used to connect telecom or data-com equipment are point to point links.

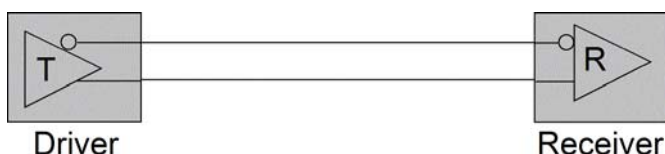

The converter can convert an RS-232 device into a **Driver** node in this point-to-point circuit.

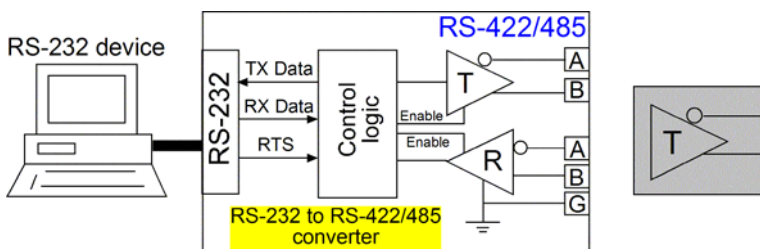

The configuration is:

SW1-4	TXE	Enable Driver always
SW1-6	RXC	Enable Receiver RTS/ADC Control
SW1-5	RTS-D	Disable RTS control
SW2-1	SDD	Disable ADC control

It also can convert an RS-232 device into a receiver node in this point-to-point circuit.

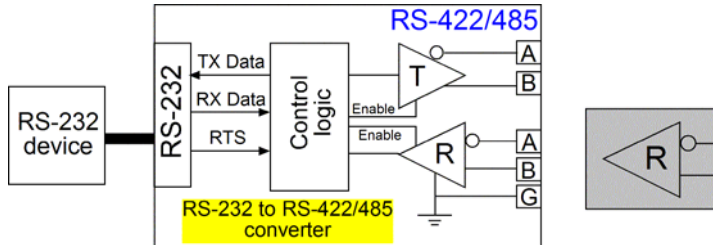

The configuration for a RECEIVER node is:

SW1-4	TXC	Enable RTS/ADC Control for Driver
SW1-6	RXE	Enable Receiver always
SW1-5	RTS-D	Disable RTS control
SW2-1	SDD	Disable ADC control

3.2 RS-422 Multi-drop Network

In this topology there is only one driver sending to one or more receivers. One termination resistor is recommended at the extreme end of the bus to eliminate reflections. Up to 10 receivers are permitted under RS-422. Multiple receive-only nodes may be used for point-to-multipoint communications.

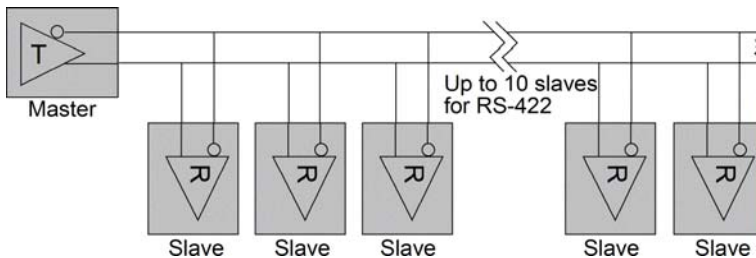

The converter can convert an RS-232 device into a **Master** node in this multi-drop network.

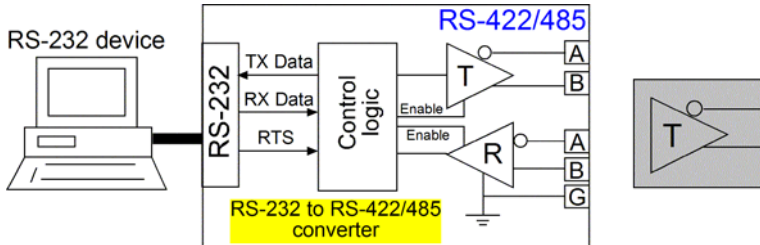

The configuration for MASTER node is:

SW1-4	TXE	Enable Driver always
SW1-6	RXC	Enable Receiver RTS/ADC Control
SW1-5	RTS-D	Disable RTS control
SW2-1	SDD	Disable ADC control

It also can convert an RS-232 device into a **SLAVE** node in this multi-drop network.

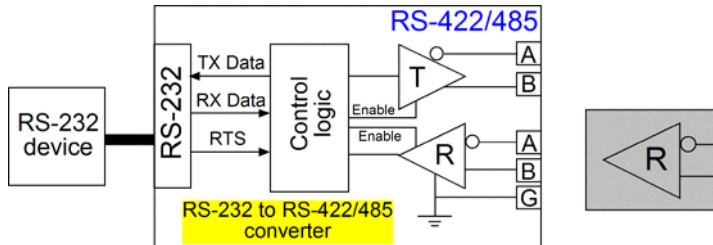

The configuration for a SLAVE node is:

SW1-4	TXC	Enable RTS/ADC Control for Driver
SW1-6	RXE	Enable Receiver always
SW1-5	RTS-D	Disable RTS control
SW2-1	SDD	Disable ADC control

3.3 RS-485 Multi-drop Network

This topology is similar to RS-422 multi-drop. However, up to 32 receivers are permitted under RS-485. This may be used for point-to-multipoint communications.

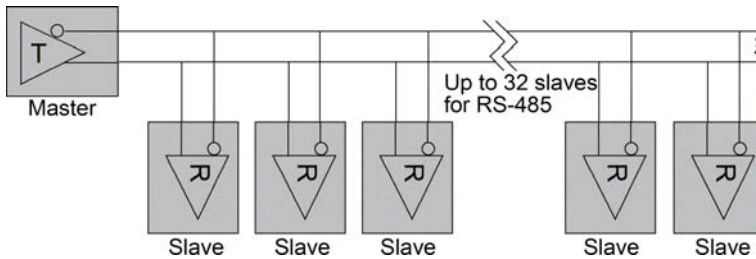

The converter can convert an RS-232 device into a [Master](#) node in this multi-drop network as illustrated below:

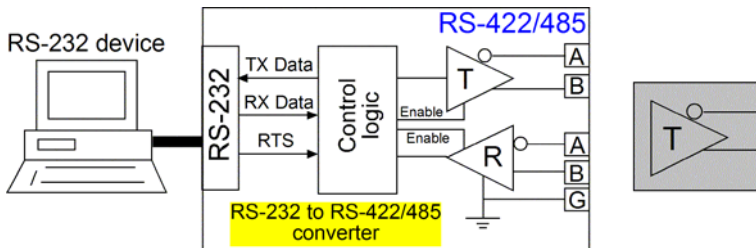

The configuration for MASTER node is:

SW1-4	TXE	Enable Driver always
SW1-6	RXC	Enable Receiver RTS/ADC Control
SW1-5	RTS-D	Disable RTS control
SW2-1	SDD	Disable ADC control

It is also able to convert an RS-232 device into a SLAVE node in this multi-drop network.

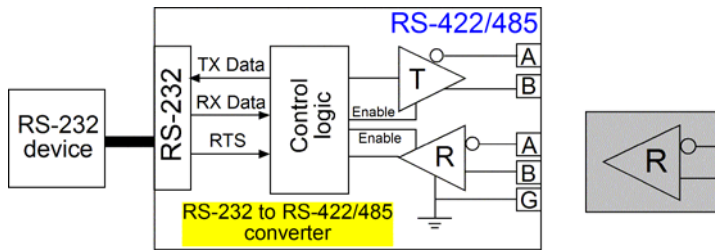

The configuration for a SLAVE node is:

- | | | |
|-------|-------|-----------------------------------|
| SW1-4 | TXC | Enable RTS/ADC Control for Driver |
| SW1-6 | RXE | Enable Receiver always |
| SW1-5 | RTS-D | Disable RTS control |
| SW2-1 | SDD | Disable ADC control |

3.4 RS-485 Half-duplex 2-wire Network

This is the typical RS-485 topology. It takes advantage of RS-485 capability to support multiple drivers on a bus. RS-422 devices should not be used in this configuration. This topology enables bidirectional communication from many nodes over long distances at low to medium data rates, all on a single pair of wires (2-wire).

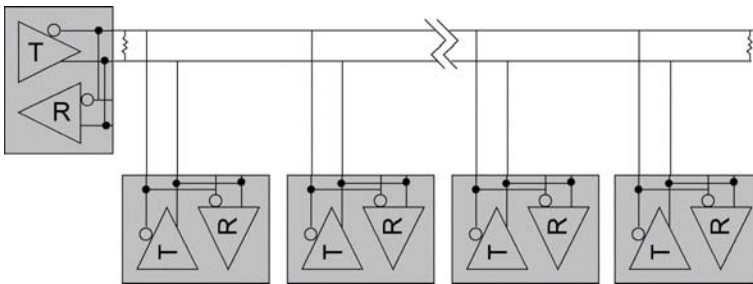

It can implement a very functional, very flexible and very economical data network. Because signals travel in both directions, this bus should be terminated at both ends to prevent reflections. Only one node can drive the bus at a time, making this a half-duplex communication channel. Only one driver should be active at any one time. Therefore the transceivers used on a half-duplex bus should support a [Driver Enable](#) function.

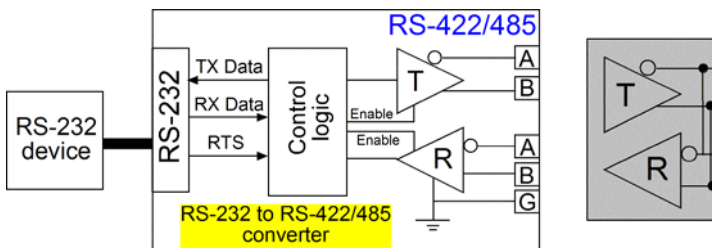

The converter features RS-485 driver and receiver in one device. It also provides very flexible configuration settings for Driver Enable control and Receiver Enable control. The configuration for the node in RS-485 2-wire network is:

SW1-2&1	2W	Select 2-wire topology
SW1-4	TXC	Enable RTS/ADC Control for Driver
SW1-6	RXC	Enable RTS/ADC Control for Receiver
SW1-5	RTS-E	Use RTS control (optional)
SW2-1	SDE	Use ADC control (optional)
SW2-2-8	Baud	Baud when ADC control is enabled (optional)
SW1-3	T-D	Disable internal terminator (optional)

3.5 RS-485 Full-duplex 4-wire Network

The 4-wire network simplifies bus arbitration in multi-node RS-485. A single Master node is the only driver allowed on the top most wire pair. All other nodes listen to all data traffic that passes on the party-line type multi-drop bus. Nodes may transmit on the lower pair of wires when addressed by the master node or by using a software token-passing bus arbitration scheme.

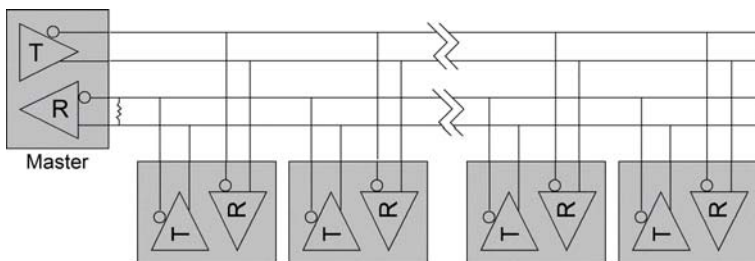

The master node may drive its bus while any of the slave nodes are driving the lower pair, making this 4-wire network a full-duplex communication channel. All communication occurs from master to slave or slave to master, so any peer to peer communications must be routed through the master node.

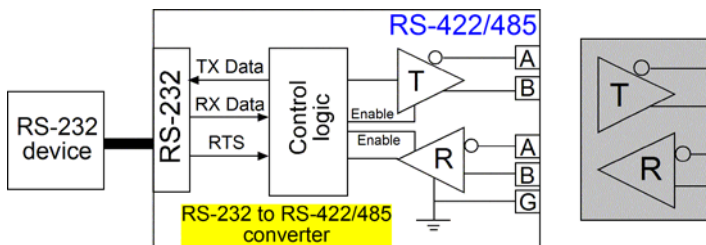

To convert an RS-232 device into a Master node in RS-485 4-wire network, the configuration is:

SW1-2&1	4W	Select 4-wire topology
SW1-4	TXE	Enable Driver always
SW1-6	RXC	Enable RTS/ADC Control for Receiver
SW1-5	RTS-E	Use RTS control (optional)
SW2-1	SDE	Or use ADC control (optional)
SW2-2-8	Baud	Baud when ADC control is enabled (optional)
SW1-3	T-D	Disable internal terminator (optional)

To convert an RS-232 device into a Slave node in RS-485 4-wire network, the configuration is:

SW1-2&1	4W	Select 4-wire topology
SW1-4	TXC	Enable RTS/ADC Control for Driver
SW1-6	RXE	Enable Receiver always
SW1-5	RTS-E	Use RTS control (optional)
SW2-1	SDE	Or use ADC control (optional)
SW2-2-8	Baud	Baud when ADC control is enabled (optional)
SW1-3	T-D	Disable internal terminator (optional)

3.6 Summary of the Converter Applications

The common topologies implemented with RS-485 and RS-422 are:

1. RS-422 point to point in 2 -wire circuit
2. RS-422 2-wire multi-drop network
3. RS-485 2-wire multi-drop network
4. RS-485 half-duplex bidirectional network in 2-wire topology
5. RS-485 full-duplex bidirectional network in 4-wire topology

The converter is equipped with functionality and flexibility to convert an RS-232 device to a node in any one of the above topologies.

4 LED Indicators

The following figure shows the locations of the LED indicators:

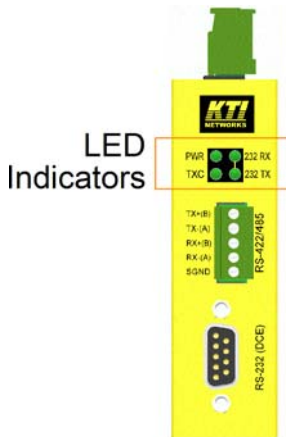

4.1 LED Indicators

<u>LED</u>	<u>DISPLAY</u>	<u>STATE</u>	<u>INTERPRETATION</u>
PWR	Power status	ON OFF	The device is powered on. The device is powered off.
232 TX	RS-232 TX	ON OFF	RS-232 TX data is present No RS-232 TX data
232 RX	RS-232 RX	ON OFF	RS-232 RX data is present No RS-232 RX data
TXC	RS-485 Driver Enable	ON OFF	The driver is enabled. The driver is disabled and is in tri-state (high-impedance).

5 Factory Default Configuration

The following table lists the factory default settings for configuration DIPSW:

<u>SW</u>	<u>Name</u>	<u>Default Setting</u>
SW1-2&1	4W	4-wire (RS-485/422 driver receiver separated)
SW1-3	T-D(Off)	Disable RS-485/422 receiver terminator
SW1-4	TXC (Off)	RS-485/422 driver enable control by RTS or ADC
SW1-5	RTS-D (Off)	Disable RTS control for RS-485/422 driver
SW1-6	RXC (Off)	RS-485/422 receiver enable control by RTS or ADC
SW1-8&7	BIAS-D (Off)	Disable RS-485/422 line bias
SW2-1	SDE (On)	Enable ADC control for RS-485/422 driver
SW2-2	Off	Disable ADC Timing for RS-232 baud 1200
SW2-3	Off	Disable ADC Timing for RS-232 baud 2400
SW2-4	Off	Disable ADC Timing for RS-232 baud 4800
SW2-5	9600 (On)	Select ADC Timing for RS-232 baud 9600
SW2-6	Off	Disable ADC Timing for RS-232 baud 19200
SW2-7	Off	Disable ADC Timing for RS-232 baud 38400
SW2-8	Off	Disable ADC Timing for RS-232 baud 115200